

Deliverable 6

Drawings, Plans, and Revised Schedule

Team GM2

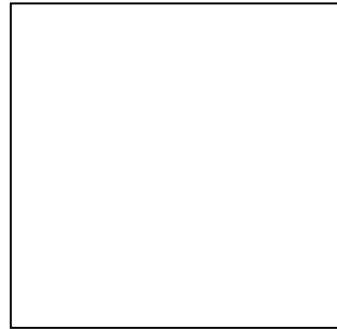

Lane Ballard

Amber Mazooji

Tom Burns

Minja Penttila

John Celmins

Chris Piscitelli

Paul Glomski

Tomer Posner

Tray Table 3D-Positional View

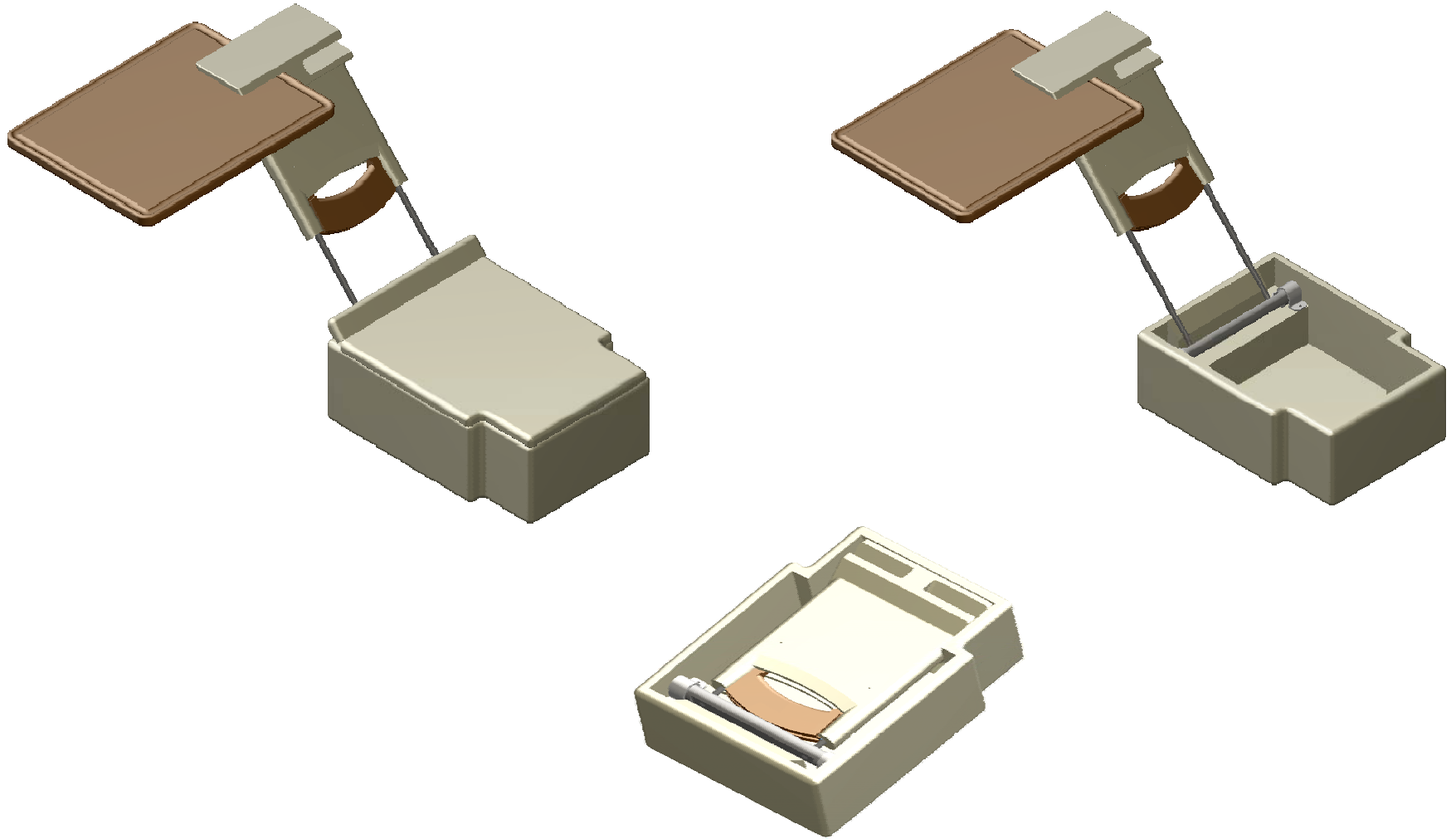

Closed Position

Armature – 3D View

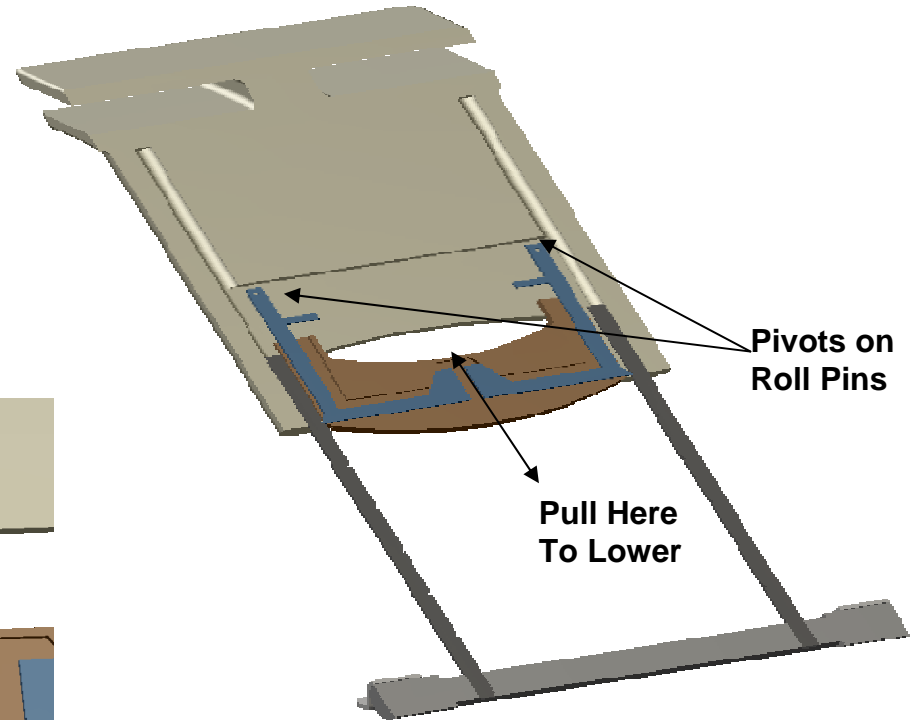
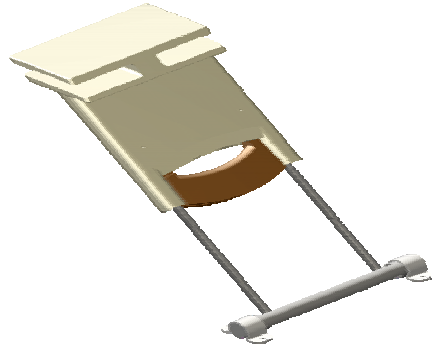

Post Retains Spring

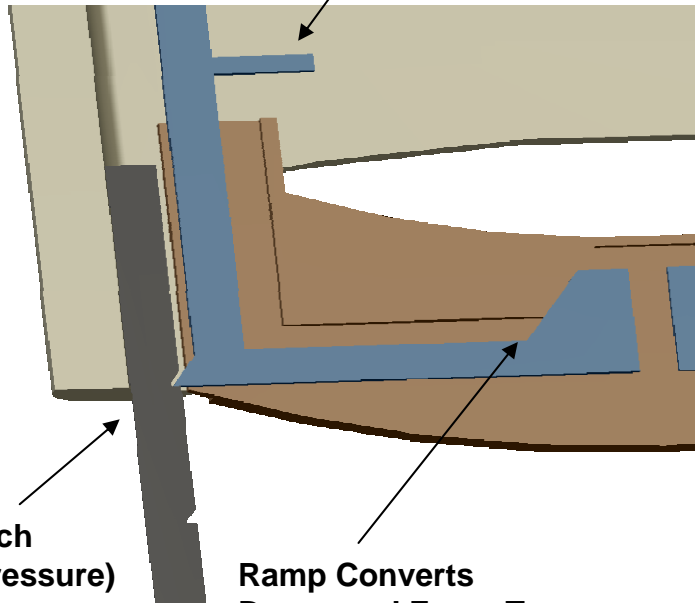

Ratchet Latch
(spring retains pressure)

Ramp Converts
Downward Force To
Inward Force

ZONE		REV	REVISIONS	DATE	APPROVED
			DESCRIPTION		

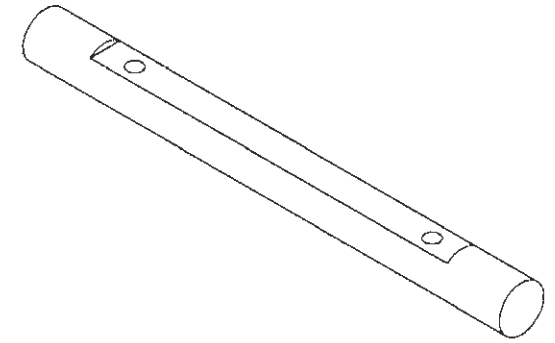
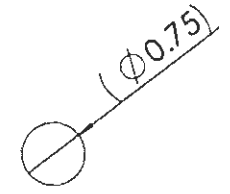
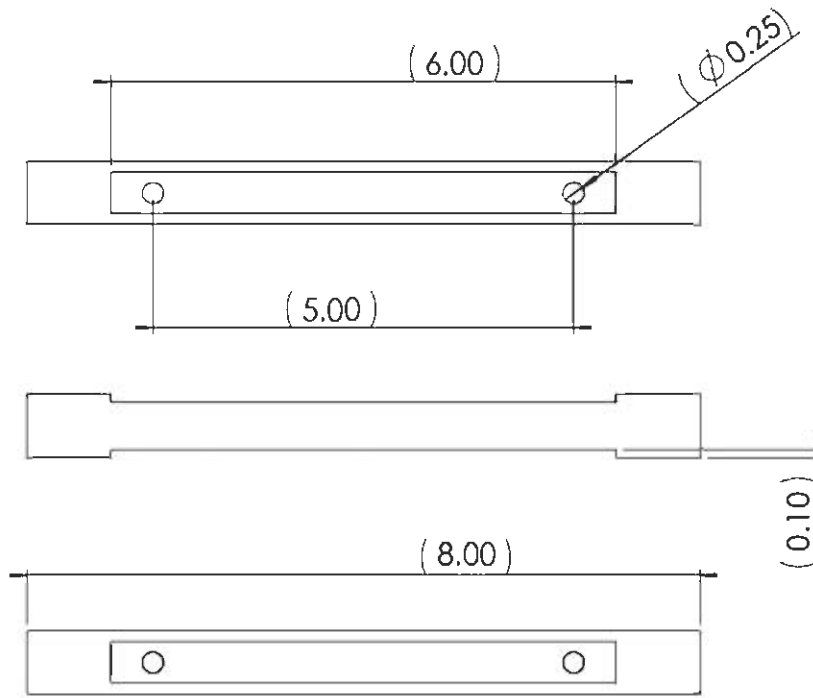

PROPRIETARY AND CONFIDENTIAL
 THE INFORMATION CONTAINED IN THIS DRAWING IS THE SOLE PROPERTY OF GM AND GENERAL MOTORS. ANY REPRODUCTION IN PART OR AS A WHOLE WITHOUT THE WRITTEN PERMISSION OF 15.783 GM2 TEAM IS PROHIBITED.

		DIMENSIONS ARE IN INCHES		NAME	DATE
		TOLERANCES:		DRAWN	
		FRACTIONAL ±		CHECKED	
		ANGULAR: MACH ± BEND ±		ENG APPR	
		TWO PLACE DECIMAL ±		MFG APPR	
		THREE PLACE DECIMAL ±		I.Q.A.	
		MATERIAL		COMMENTS	
NEXT ASSY	USED ON	FINISH			
APPLICATION		DO NOT SCALE DRAWING			

NAME	DATE
DRAWN	
CHECKED	
ENG APPR	
MFG APPR	
I.Q.A.	
COMMENTS	

GM2 - TRAY TABLE		REV
PIVOT BAR		
SIZE	DWG. NO.	REV
A		
SCALE 1:2	WEIGHT	SHEET 1 OF 1

REV		REVISION	DATE	APPROVED
DATE	REV	DESCRIPTION	DATE	APPROVED

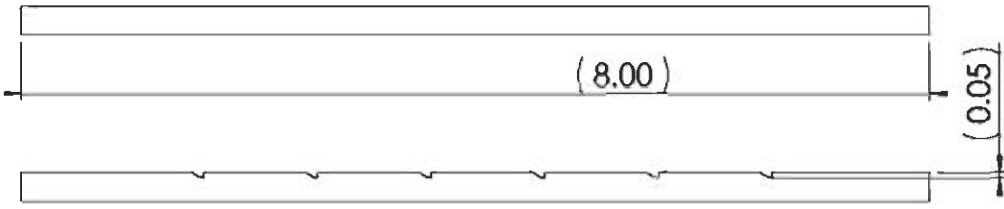

$\varnothing 0.25$

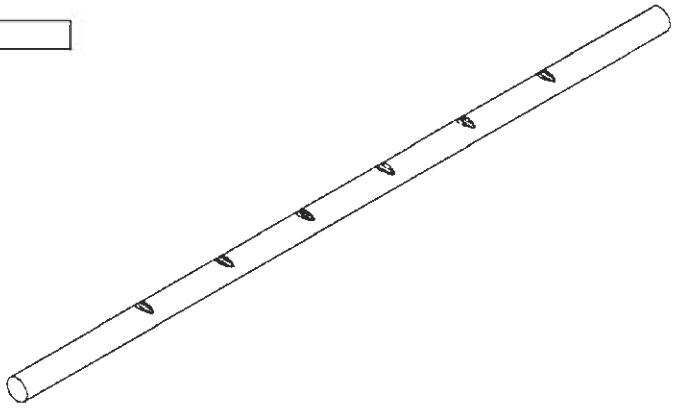
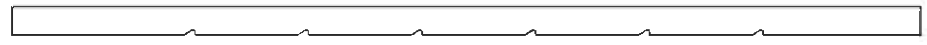
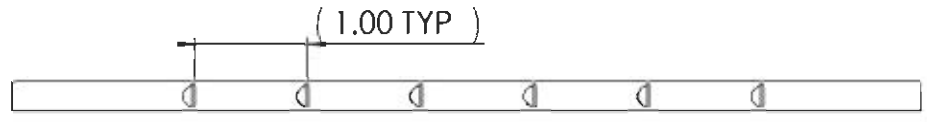

PROPRIETARY AND CONFIDENTIAL
 THE INFORMATION CONTAINED IN THIS DRAWING IS THE SOLE PROPERTY OF GM AND GENERAL MOTORS. ANY REPRODUCTION IN PART OR AS A WHOLE WITHOUT THE WRITTEN PERMISSION OF 15.783 GM2 TEAM IS PROHIBITED.

DIMENSIONS ARE IN INCHES		NAME	DATE
TOLERANCES:		DRAWN	
FRACTIONAL ±		CHECKED	
ANGULAR: MACH ± BEND ±		ENG APPR	
TWO PLACE DECIMAL ±		MFG APPR	
THREE PLACE DECIMAL ±		Q A	
MATERIAL --		COMMENTS	
NEXT ASSY	USED ON		
FINISH --			
APPLICATION		DO NOT SCALE DRAWING	

GM2 - TRAY TABLE
RATCHET POST

SIZE	DWG. NO.	
A		
SCALE 2:3	WEIGHT	SHEET 1 OF 1

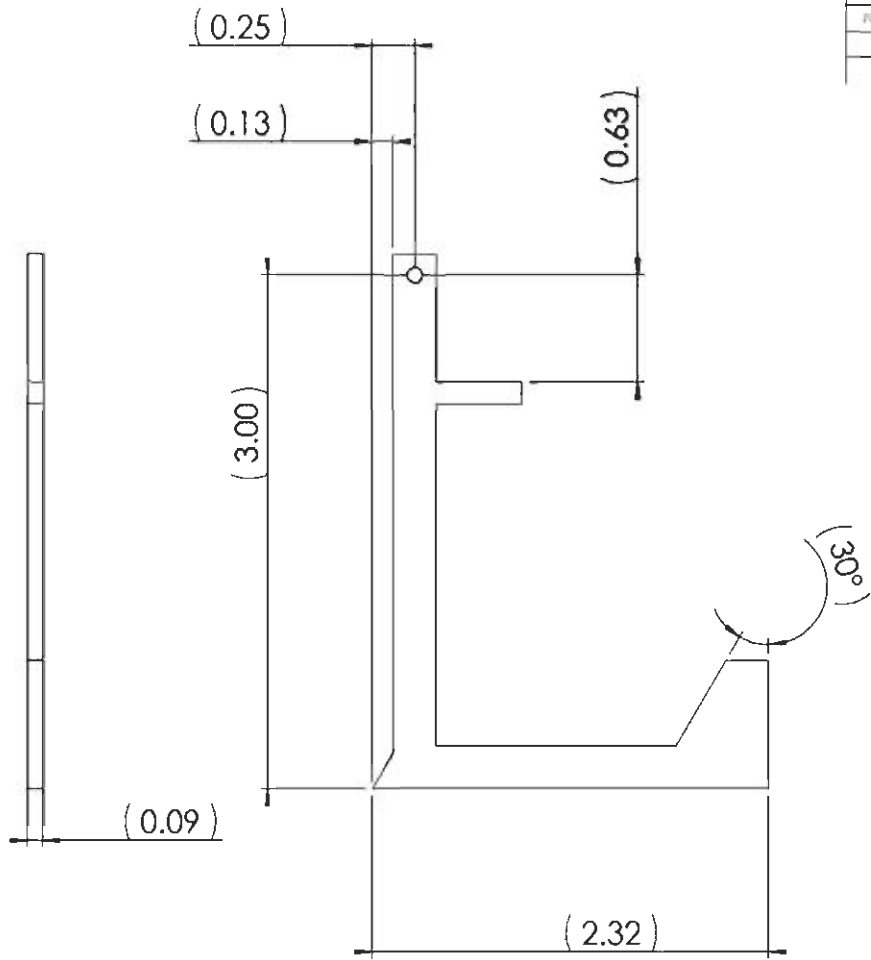

REV		DESCRIPTION	DATE	APPROVED

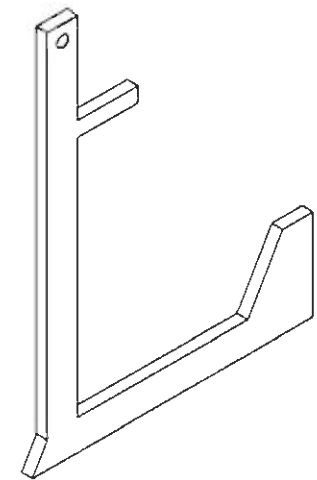

PROPRIETARY AND CONFIDENTIAL
 THE INFORMATION CONTAINED IN THIS DRAWING IS THE SOLE PROPERTY OF MT AND GENERAL MOTORS. ANY REPRODUCTION IN PART OR AS A WHOLE WITHOUT THE WRITTEN PERMISSION OF 13.783 GM2 TEAM IS PROHIBITED.

DIMENSIONS ARE IN INCHES		NAME	DATE
TOLERANCES:		DRAWN	
FRACTIONAL ±		CHECKED	
ANGULAR: MACH ±		ENG APPR	
TWO PLACE DECIMAL ±		MFG APPR	
THREE PLACE DECIMAL ±		Q.A.	
MATERIAL		COMMENTS	
FINISH			
NEXT ASSY	USED ON		
APPLICATION	DO NOT SCALE DRAWING		

GM2 - TRAY TABLE	
RATCHET	
SIZE	DWG. NO.
A	
SCALE 1:1	WEIGHT
SHEET 1 OF 1	

ZONE		REV	REVISIONS	DATE	APPROVED
			DESCRIPTION		



SCALE 1:1

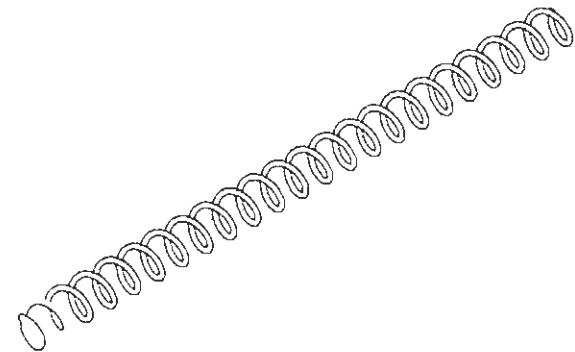

PROPRIETARY AND CONFIDENTIAL
 THE INFORMATION CONTAINED IN THIS DRAWING IS THE SOLE PROPERTY OF GM AND GENERAL MOTORS. ANY REPRODUCTION IN PART OR AS A WHOLE WITHOUT THE WRITTEN PERMISSION OF 15.783 GM2 TEAM IS PROHIBITED.

		DIMENSIONS ARE IN INCHES		NAME	DATE
		TOLERANCES:		DRAWN	
		FRACTIONAL: \pm		CHECKED	
		ANGULAR: MACH: \pm BEND: \pm		ENG APPR	
		TWO PLACE DECIMAL: \pm		MFG APPR	
		THREE PLACE DECIMAL: \pm		G.A.	
		MATERIAL: --		COMMENTS	
		FINISH: --			
NEXT ASSY	USED ON				
APPLICATION	DO NOT SCALE DRAWING				

GM2 - TRAY TABLE		REV
COMPRESSION SPRING		
SHEET NO	DWG. NO	REV
A		
SCALE 1:1	WEIGHT	SHEET 1 OF 1

ZONE		REV	REVISION	DATE	APPROVED
			DESCRIPTION		

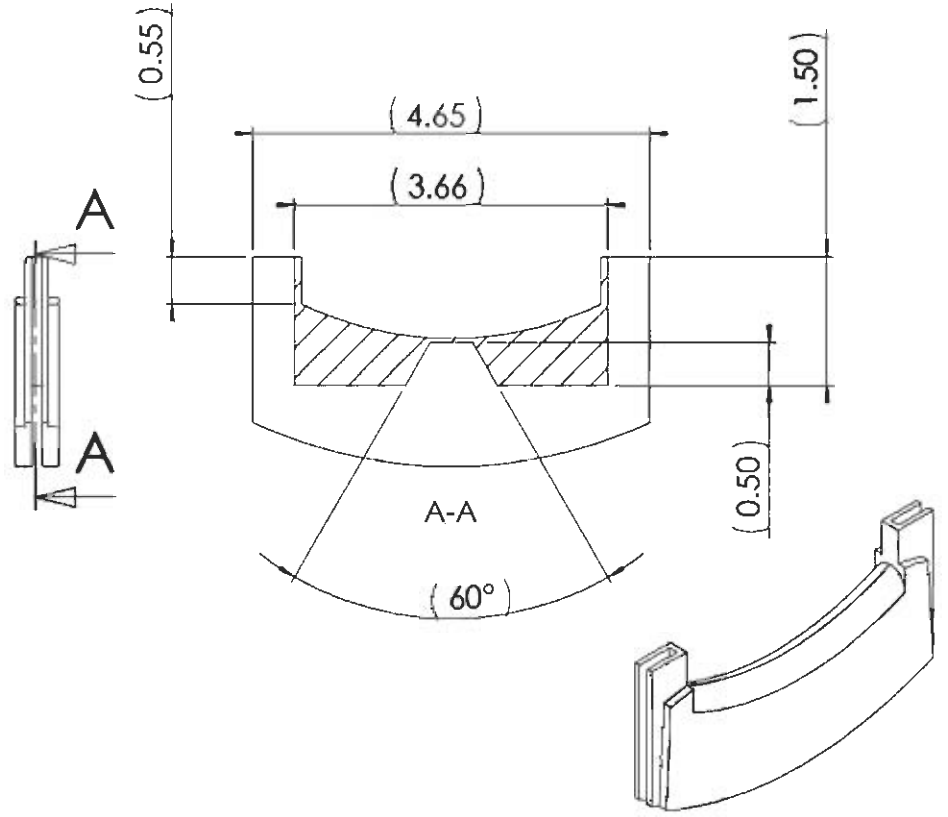
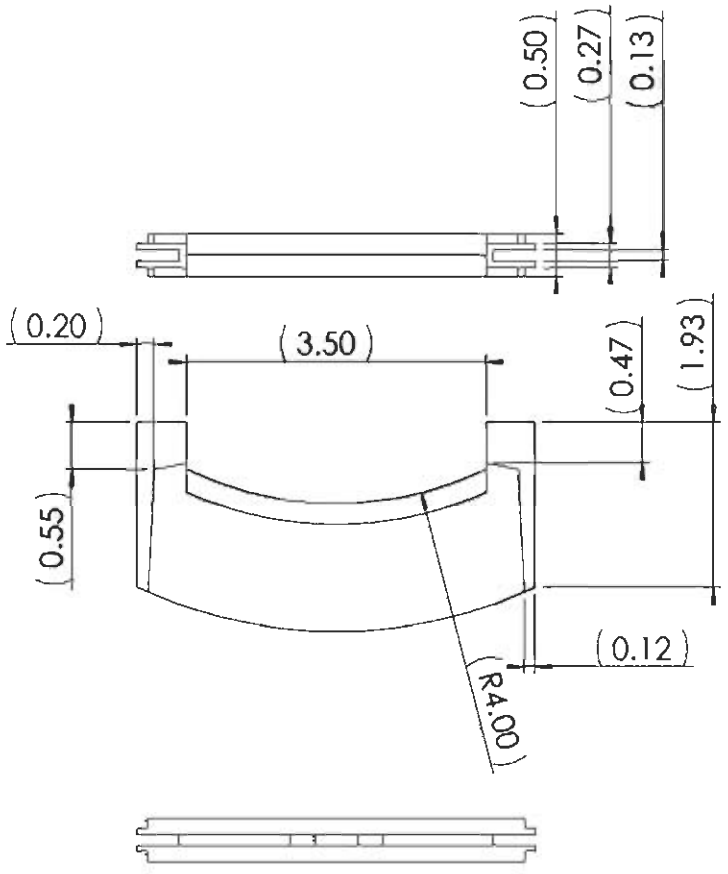

PROPRIETARY AND CONFIDENTIAL
 THE INFORMATION CONTAINED IN THIS DRAWING IS THE SOLE PROPERTY OF GM AND GENERAL MOTORS. ANY REPRODUCTION IN PART OR AS A WHOLE WITHOUT THE WRITTEN PERMISSION OF 15.783 GM2 TEAM IS PROHIBITED.

		DIMENSIONS ARE IN INCHES	NAME	DATE
		TOLERANCES:	DRAWN	
		FRACTIONAL ±	CHECKED	
		ANGULAR: MACH ± BEND ±	ENG APPR	
		TWO PLACE DECIMAL ±	MFG APPR	
		THREE PLACE DECIMAL ±	G.A.	
		MATERIAL	COMMENTS:	
		FINISH		
NEXT ASSY	USED ON			
APPLICATION	DO NOT SCALE DRAWING			

GM2 - TRAY TABLE		
RELEASE HANDLE		
SIZE	DWG NO.	REV
A		
SCALE: 1:2	WEIGHT	SHEET 1 OF 1

ZONE		REV	DESCRIPTION	DATE	APPROVED

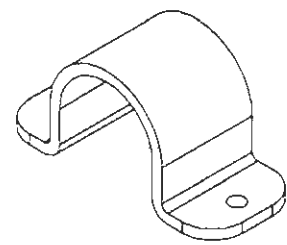
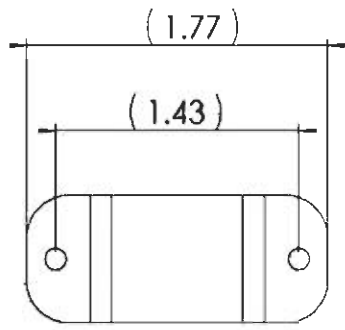
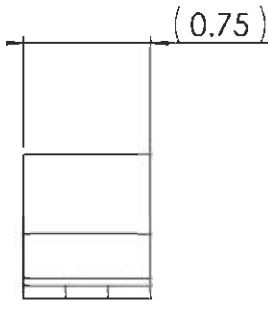
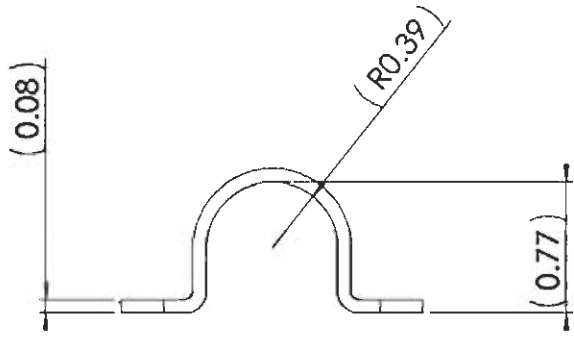

PROPRIETARY AND CONFIDENTIAL
 THE INFORMATION CONTAINED IN THIS DRAWING IS THE SOLE PROPERTY OF GM AND GENERAL MOTORS. ANY REPRODUCTION IN PART OR AS A WHOLE WITHOUT THE WRITTEN PERMISSION OF 15.783 GM2 TEAM IS PROHIBITED.

		DIMENSIONS ARE IN INCHES TOLERANCES: FRACTIONAL ± ANGULAR, MACH ± BEND ± TWO PLACE DECIMAL ± THREE PLACE DECIMAL ±	NAME	DATE
			DRAWN	
			CHECKED	
			ENG APPR	
			MFG APPR	
		MATERIAL		
		FINISH		
NEXT ASSY	USED ON		COMMENTS	
APPLICATION	DO NOT SCALE DRAWING			

GM2 - TRAY TABLE	
PIVOT BRACKET	
REV	DATE
A	
SCALE 1:1	WEIGHT
SHEET 1 OF 1	

ZONE		REV	REVISIONS	DATE	APPROVED
			DESCRIPTION		

(1.09)

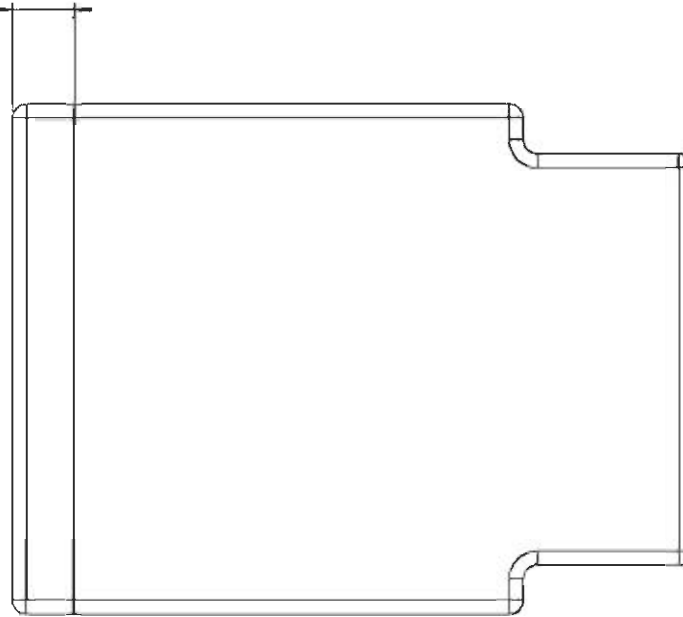

(0.50)



PROPRIETARY AND CONFIDENTIAL
 THE INFORMATION CONTAINED IN THIS DRAWING IS THE SOLE PROPERTY OF GM AND GENERAL MOTORS. ANY REPRODUCTION IN PART OR AS A WHOLE WITHOUT THE WRITTEN PERMISSION OF 15.783 GM2 TEAM IS PROHIBITED.

			DIMENSIONS ARE IN INCHES		NAME	DATE
			TOLERANCES:		DRAWN	
			FRACTIONAL ±		CHECKED	
			ANGULAR: MACH ±	BEND ±	ENG APPR	
			TWO PLACE DECIMAL ±		MFG APPR	
			THREE PLACE DECIMAL ±		D.A.	
			MATERIAL	---	COMMENTS	
			FINISH	---		
NEXT ASSY	USED ON					
APPLICATION		DO NOT SCALE DRAWING				

GM2 - TRAY TABLE

ARM TOP

SIZE	DWG. NO.	
A		
SCALE 1:1	@BOM	

C

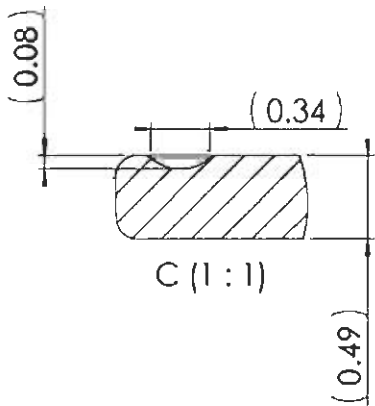
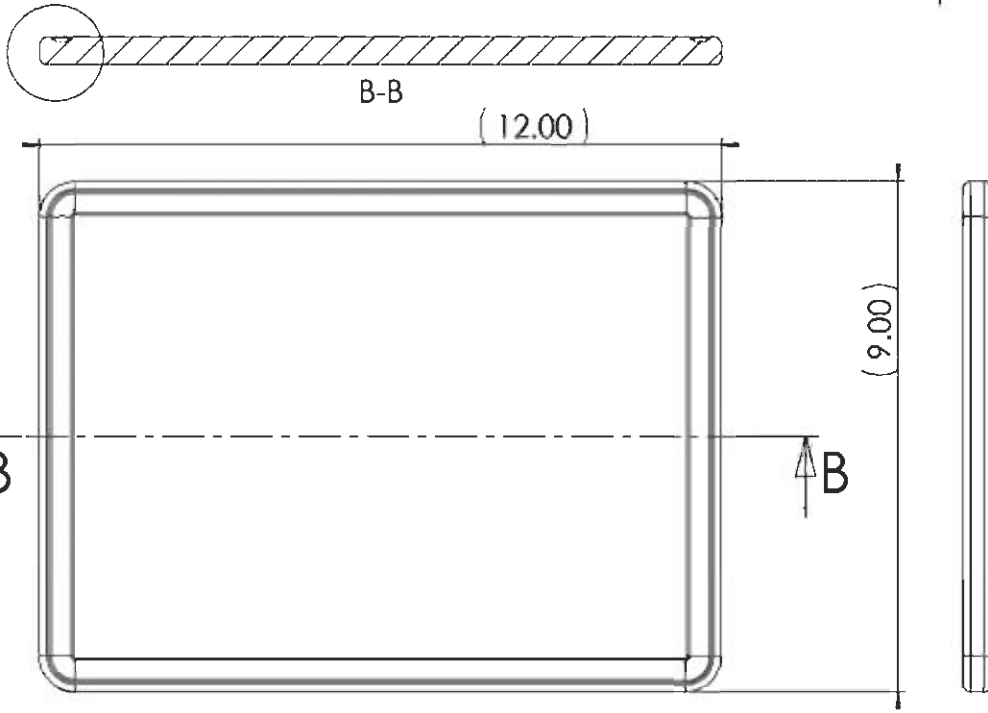

ZONE		REV		REVISIONS	DATE	APPROVED
				DESCRIPTION		

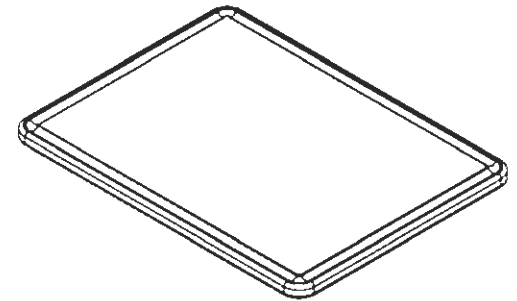

PROPRIETARY AND CONFIDENTIAL
 THE INFORMATION CONTAINED IN THIS DRAWING IS THE SOLE PROPERTY OF TST AND GENERAL MOTORS. ANY REPRODUCTION IN PART OR AS A WHOLE WITHOUT THE WRITTEN PERMISSION OF 35.783 GM2 TEAM IS PROHIBITED.

		DIMENSIONS ARE IN INCHES		NAME	DATE	GM2 - TRAY TABLE
		TOLERANCES:				
		FRACTIONAL ±		DRAWN		
		ANGULAR: MATCH ± BEND ±		CHECKED		
		TWO PLACE DECIMAL ±		ENG APPR		
		THREE PLACE DECIMAL ±		MFG APPR		
		MATERIAL	--	Q A		
		FINISH	--	COMMENTS		
NEXT ASSY	USED ON					
APPLICATION	DO NOT SCALE DRAWING					
				TST DWG NO		REV
				A		
				SCALE 1:3	WEIGHT	SHEET 1 OF 1

Structural Analysis

The loads we predict for the tray-table are much too small to cause failure or breakage. Our main concern is for the flexure of the system during usage.







The rods and table are each unlikely to show much bending, as shown by the calculations below:

Assuming a 50 Newton force (~5kg weight) spread along a line parallel to the sides of the table, 25cm from attachment point

		Comments / Formulas / Sources
Load	50 Newtons	(at center of mass of table)
Table		
Length	0.5 Meters	(runs L-R for passenger)
Width	0.2 Meters	
Thickness	0.0125 Meters	
Rod		
Radius	0.005 Meters	
Length	0.2 Meters	
Max table flex (assuming only table flexes)		
Beam bending (simply supported, loaded in the middle)		
Moment of inertia	3.2552E-08 kg*m ²	=Width*Thickness ³ /12
Wood Young's Modulus	1.5E+10 Pa	www.physics.usyd.edu.au/teach_res/db/d0004c.htm
Y (max deflection) for bar loaded in center	-0.000267 Meters -0.0267 Cm	www.polymorf.net/engineer19.htm = - F*L ³ /(48*E*I)
Max rod flex (assuming only rod flexes)		
Rod bending (simply supported, loaded at the end)		
Moment of inertia	4.9087E-10 kg*m ²	=pi*r ⁴ /4 www.efunda.com/math/areas/Circle.cfm
Steel Young's Modulus	2E+11 Pa	
Y max deflection	-0.0001698 Meters -0.0170 Cm	www.polymorf.net/engineer19.htm = - F*L ³ /(48*E*I)

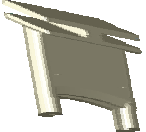
The deflections derived are quite insignificant for our product. Instead, we believe that the real danger for the table "giving" under loading are the interfaces between the components. We paid special attention to these in our detailed design, and intend to build the prototype in a way that will prove this physically.

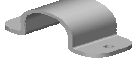
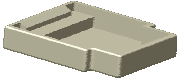
Bill of Materials (BOM)

Part Number	Part Name	Quantity	Image	Prototype Material	Prototype Manufacture
1	Pivot Bar	1		Alumimun Round Stock	Mill
2	Ratchet Post	2		Steel	
3	Ratchet	2		ABS	Mill
4	Roll Pin	2		Steel	Purchased
5	Compression Spring	1		Steel	Purchased
6	Upper Bracket	1		Alumimun Billet	Mill
7	Release Handle	1		Ren	Machined
8	Pivot Bracket	2		Steel	Purchased
9	Arm Bottom	1		Arm	Purchased
10	Arm Top	1		Arm	Purchased
11	Executive Tray	1		Wood	
12	Activity Tray	1		Wood	

Prototype Work

Summary of important decisions

Since assignment 5, we have made a few key decisions. We thoroughly investigated developing a tray table system that stows entirely within the armrest – the team performed a feasibility analysis, and worked to mock up possible solutions. We decided however to continue with the existing design due to continued customer interviews and the constraints of the integral design.

The Bill of Materials (BOM) includes the required manufacturing processes. We have purchased a standard Cadillac SRX armrest, and plan to manufacture most of the rest of the pieces, as noted in the BOM.

Web resources:

McMaster offers a wide range of products and supplies:

<http://www.mcmaster.com>

We purchased an arm rest from a Cadillac dealer found on the Cadillac corporate web site. The purchase was necessary because we have yet to receive parts directly from GM.

<http://www.cadillac.com/>

Production Sketch



Production Sketch

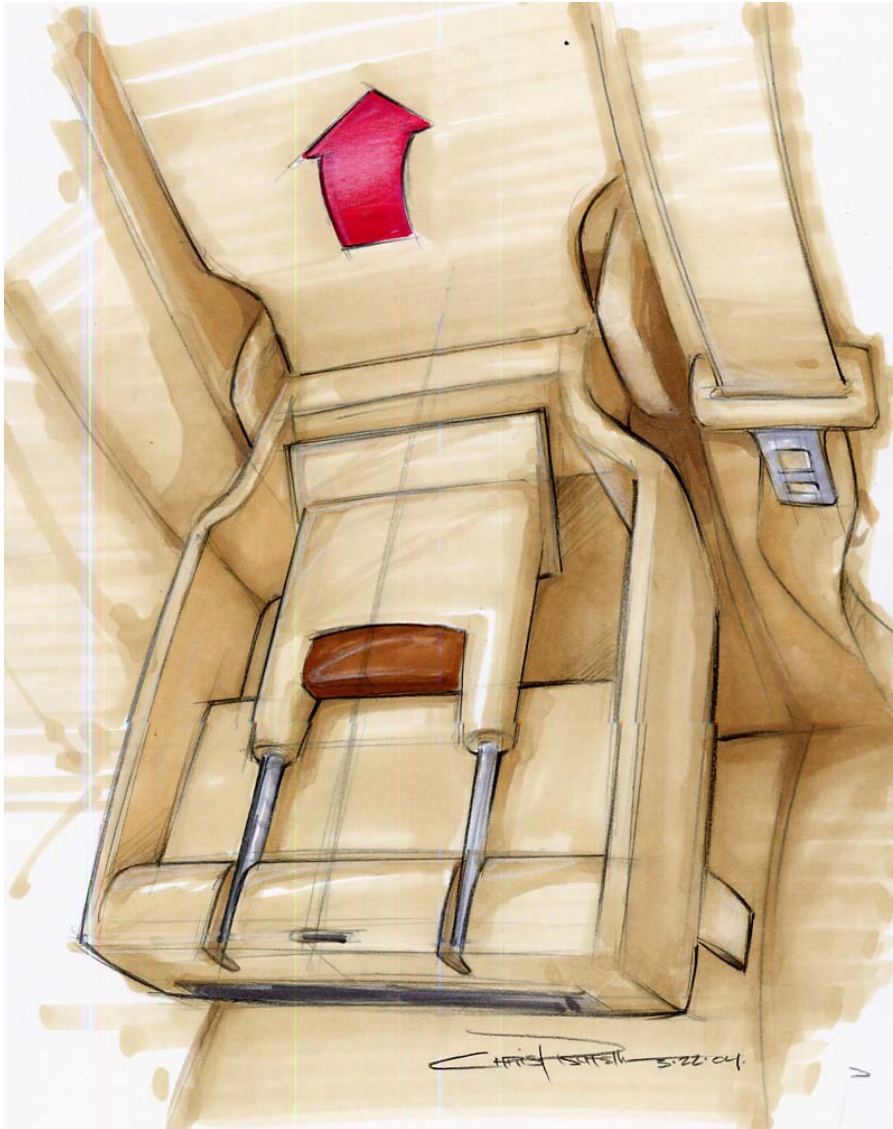

Production Version Changes Include

- **Material Choices**
 - upper bracket inj mold glass filled
 - handle inj mold w/burl
- **Finished Detail of Arm**
- **Second Tray Option**
- **Cup Holders Added**

Updated Schedule

GM Lap Tray - Team #2

Page 1 of 1

4/12/04

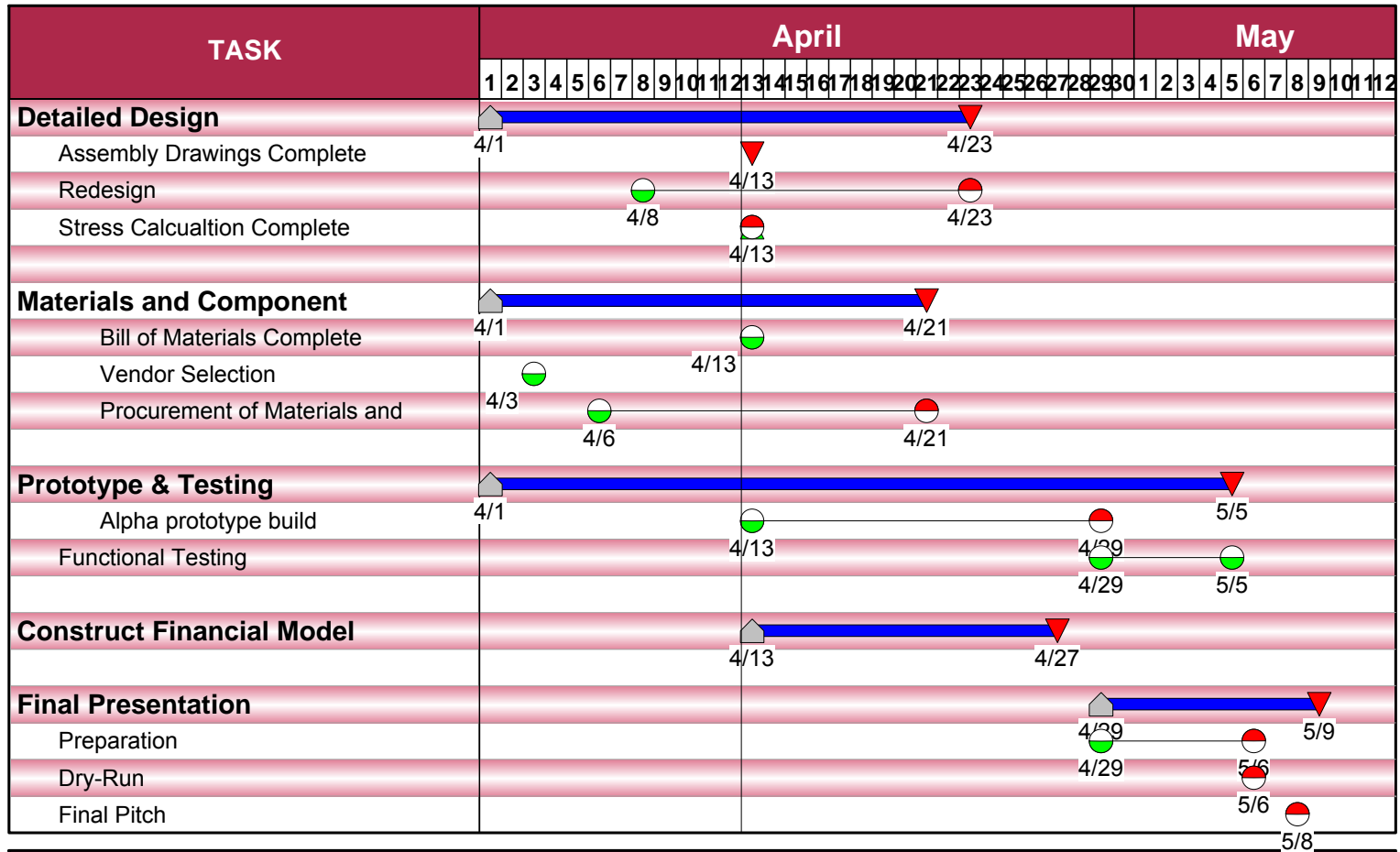

Process Notes

Process Reflection

- The major difficulty in this period was to decide whether to stay with the original concept idea of detachable table after receiving critique during both the GM presentation and advisor meetings. To assist the decision making, the team conducted yet another customer survey focusing on target customer market of “soccer mums”. The results showed, that nobody in our target market would not buy the table because it is detachable. The table would mainly be used during longer trips, in which case slightly more complicated “assembly” was not seen as a problem. Customers noted that a detachable table would be easy to clean and replace if broken. Customers also mentioned that the concept would enable different tray tops for different purposes. The main disadvantage was the fear of loosing the table.
- While the team realizes the many challenges, it was unanimously decided to stay with the selected concept. The reasons were:
 - lack of time and resources to come up with an attached mechanism within the armrest that would meet the “must have” customer needs, such as aesthetically pleasing, durable, and useful for children
 - Importance of providing GM an alternative concept different from that of the other team’s
 - encouraging feedback from target customer market
 - the ability to accommodate big enough tray table, as indicated by the customer surveys
- For the product to be accepted by target market, it needs to have the feel of German quality, low enough price and good functionality (large enough table to fit a coloring book). The team also faces the challenge how to convince the audience during final presentations. The major risk for the selected concept is therefore uncertainty in customer survey information accuracy.
- Another issue, which is typical of the product development process, was lack of perfect information. To address this, the team purchased an armrest from a Cadillac dealer.

Group Meetings 3/30, 4/1/2004

- Team was not in full strength due to holidays and illnesses. However, feedback from the GM presentation was seriously discussed, and viability of our concept questioned. It was decided to conduct a customer survey with concept pictures, to compare the feedback from GM with input from the target market.
- Individual tasks for the next lengthy assignment were divided.

Group Meeting – 4/6/2004

- Paul reviewed customer survey and interview feedback. After lengthy discussion of pros and cons the team members decided to stay with the existing concept.
- The materials for final prototype were discussed; team decided to make a prototype that would provide the “wow” factor from an aesthetics standpoint, but also provide enough functionality to demonstrate the concept. The team had not yet identified a machine shop to do the final prototype.

Group Meeting – 8/4/2004

- Tomer managed to secure us the opportunity to use graduate students’ mechanical workshop.
- The schedule for assignment was checked and the team reviewed the status of the CAD drawings.
- Seats were still not available, but the team remained hopeful to receive a sample arm rest to use in building the final prototype.

Advisor Meeting – 8/4/2004

- The team met with Roemer, Kressy and Whitney to discuss the status of the project. Roemer and Kressy questioned the feasibility of the detachable concept, but understood our reasoning to go forward with it. However, they highlighted the importance of convincing our audience during the final presentation. Whitney gave good ideas for how to mechanically lock-in the table top.

MIT OpenCourseWare

<https://ocw.mit.edu>

15.783J / 2.739J Product Design and Development

Spring 2006

For information about citing these materials or our Terms of Use, visit: <https://ocw.mit.edu/terms>.