

Massachusetts Institute of Technology

22.68J/2.64J

Superconducting Magnets



February 27, 2003

- Lecture #4 – Magnetic Forces and Stresses

Forces

- For a solenoid, energy stored in the magnetic field acts equivalent to an internal pressure:

$$\frac{E}{Vol} = \frac{B^2}{2\mu_0}$$

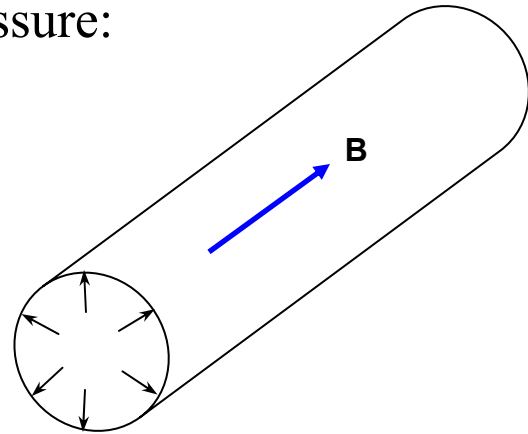

- Long, thin solenoid
- For $B = 6 \text{ T} \Rightarrow$ Internal pressure equivalent $\equiv 140 \text{ atm}$
 - (typical working pressure of a gas cylinder)
- For $B = 10 \text{ T} \Rightarrow P = 400 \text{ atm}$, the yield stress of copper

Impact of Forces

- Can break the structure and destroy the magnet.
- Can damage insulation.
- Can damage superconductor including overstraining brittle Nb₃Sn wire.
- Can degrade magnet performance
 - motion \rightarrow release energy \rightarrow instability \rightarrow quench \rightarrow training (?)

$$\mathbf{F} = \mathbf{J} \times \mathbf{B}$$

Compute the field throughout the winding volume

- **Combine computation of forces and stress analysis with calculation of B**
 - Usually done by computer.
 - Simple analytical formulations are useful for early stages of design.
 - Must have knowledge of materials properties:
 - Mechanical
 - Thermal (COE for thermal stresses)
 - From room temperature (RT) to 4K

Forces and Stresses in Solenoids

- B is highest in axial field direction, B_z , and current is azimuthal, J_θ , so largest forces are radial \rightarrow circumferential hoop stresses
- B_r is high at coil ends \rightarrow axial compression

Analysis

- Simplest assumption: Each turn acts independently
- The a tension develops in each turn:

$$T = B(r)Ir$$

- Overall hoop stress σ_{θ}

$$\sigma_{\theta} = B(r)Jr \quad [1]$$

Where both J and σ_{θ} are averaged over the winding pack

- Thus stresses increase with B , J and r (size)

- Field distribution across a solenoid is often approximately linearly decreasing from inner radius to outer radius:

$$B = \frac{(a_2 - r)B_1 + (r - a_1)B_2}{(a_2 - a_1)}$$

$$B(\rho) = \frac{(\alpha - \rho)B_1 + (\rho - 1)B_2}{(\alpha - 1)} \quad [2]$$

Where $\rho = r/a_1$, $\alpha = a_2/a_1$

- For the special case of [an infinitely long solenoid](#), we have $B_2 = 0$ and $B_1 = \mu_0 J (a_2 - a_1)$ so that

$$\sigma_\theta = BJr = \left(\frac{B_1^2}{2\mu_0} \right) \frac{2(\alpha - \rho)\rho}{(\alpha - 1)^2} \quad [3]$$

Note that $B^2/2\mu_0$ is a scaling factor!

- Often the approximation that turns act independently is a poor approximation.
- Adjacent turns pressing on each other develop a radial stress which modifies the hoop stress.
- Assume *elastic* and *isotropic* properties
 - Then there is an analytic solution based on distributed forces in a cylinder (Timoshenko, S. (1956), Strength of Materials, Part 2)
 - Let u be the local displacement in the radial direction
 - Reduce the equilibrium condition between σ_r and σ_θ and B/r to a single equation

(Lontai & Marston (1965); and Montgomery (1969))

$$\frac{1}{r} \frac{d}{dr} \left\{ r \frac{du}{dr} \right\} - \frac{u}{r^2} = - \frac{(1-\nu^2)}{E} B/r \quad [4a]$$

With

$$\sigma_\theta = \frac{E}{1-\nu^2} \left\{ \frac{u}{r} + \nu \frac{du}{dr} \right\} \quad [4b]$$

$$\sigma_r = \frac{E}{1-\nu^2} \left\{ \frac{du}{dr} + \nu \frac{u}{r} \right\} \quad [4c]$$

Where E = Young's Modulus

ν = Poisson's Ratio

and Tensile Stress is defined to be positive (+)

- For convenience, let $r = \rho a_1$, $a_2 = \alpha a_1$, $w = uE/[a_1(1-\nu^2)]$ and $B_1 a_1 = K - M\rho$

where,

$$K = \frac{(\alpha B_1 - B_2) J a_1}{(\alpha - 1)} \quad \text{and} \quad M = \frac{(B_2 - B_1) J a_1}{(\alpha - 1)}$$

So that

$$\frac{1}{\rho} \frac{d}{d\rho} \left\{ \rho \frac{dw}{d\rho} \right\} - \frac{w}{\rho^2} = -K + M\rho \quad [5a]$$

$$\sigma_\theta = \frac{w}{\rho} + \nu \frac{dw}{d\rho} \quad [5b]$$

$$\sigma_r = \frac{dw}{d\rho} + \nu \frac{w}{\rho} \quad [5c]$$

The solution of Eqn. [5a] is:

$$w = C\rho + \frac{D}{\rho} - \frac{K\rho^2}{3} + \frac{M\rho^3}{8} \quad [6]$$

where the coefficients C and D are obtained by the boundary conditions at $r = a_1$ and a_2 , i.e., $\rho = 1$ and α .

- Depending on coil design there may be radial stress at the inner and outer boundaries, e.g.:
 - Inner winding mandrel
 - Outer pre-stress winding or structural support cylinder or ring.
- Most usual condition, though, is that the boundaries are free, i.e., $\sigma_r = 0$ at $\rho = 1$ and α .
- Substituting these conditions into [5c] and [6] allows definition of C and D and thus the stress functions:

$$\sigma_{\theta} = \frac{K(2+\nu)}{3(\alpha+1)} \left\{ \alpha^2 + \alpha + 1 + \frac{\alpha^2}{\rho^2} - \rho \frac{(1+2\nu)(\alpha+1)}{(2+\nu)} \right\} - \frac{M(3+\nu)}{8} \left\{ \alpha^2 + 1 + \frac{\alpha^2}{\rho^2} - \frac{(1+3\nu)}{(3+\nu)} \rho^2 \right\} \quad [7a]$$

$$\sigma_r = \frac{K(2+\nu)}{3(\alpha+1)} \left\{ \alpha^2 + \alpha + 1 - \frac{\alpha^2}{\rho^2} - (\alpha+1)\rho \right\} - \frac{M(3+\nu)}{8} \left\{ \alpha^2 + 1 - \frac{\alpha^2}{\rho^2} - \rho^2 \right\} \quad [7b]$$

- For the particular case of an **Infinite Solenoid**:
 $B_2 = 0$ and $\mu_0 J a_1 (\alpha - 1) = B_1$
 and assuming $\nu \approx 1/3$ (usual for most materials)

[7a] and [7b] reduce to:

$$\sigma_{\theta} = \left[\frac{B_1^2}{2\mu_0} \right] \frac{2}{(\alpha - 1)^2} \left\{ \frac{7\alpha}{9(\alpha + 1)} \right\} \left[\alpha^2 + \alpha + 1 + \frac{\alpha^2}{\rho^2} - \frac{5}{7}(\alpha + 1)\rho \right] - \frac{5}{12} \left[\alpha^2 + 1 + \frac{\alpha^2}{\rho^2} - \frac{3}{5}\rho^2 \right] \quad [8a]$$

$$\sigma_r = \left[\frac{B_1^2}{2\mu_0} \right] \frac{2}{(\alpha - 1)^2} \left\{ \frac{7\alpha}{9(\alpha + 1)} \right\} \left[\alpha^2 + \alpha + 1 - \frac{\alpha^2}{\rho^2} - (\alpha + 1)\rho \right] - \frac{5}{12} \left[\alpha^2 + 1 - \frac{\alpha^2}{\rho^2} - \rho^2 \right] \quad [8b]$$

- See Figure for σ vs ρ at different α .

- Comments

Thin Coil $\alpha = 1.3$

- Large hoop stress for unsupported turn case
- σ_r is effective in spreading out hoop stress and lowering peak value.

Medium Coil $\alpha = 1.8$

- Special case where $\sigma_{\theta} = \sigma'_{\theta}$, at $\rho = 1$, i.e., the peak hoop stress is not affected by σ_r

Fat Coil $\alpha = 4$

- Radial stress becomes tensile at inner layers. This results in doubling the hoop stress at $\rho = 1$.

Conclusions

- Radial stress is beneficial in reducing hoop stress in solenoids *if* it is compressive.
- Radial stress makes matters worse if it is *tensile*.
- Also, tensile stress is bad for insulation – film and epoxy resins cannot take much tension before cracking or separating.
 - Could cause winding delamination
 - Could lead to energy release and quenching.
- Often prestress is applied at RT during coil fabrication to maintain only radial compression under all conditions of cool-down and operating energization.
- Fig. 4.3 shows criteria derived by Middleton and Trowbridge to provide σ_r compression.

Other Considerations

- For thick windings, divide the coil into several thinner, mechanically separate, concentric sections to prevent radial tension.
- The assumption of isotropic properties (elastic) is often not good:
 - E for metals is usually much higher than E for insulating materials.
 - This makes windings ‘spongy’ in the radial direction.
- Axial forces always cause compressive stresses and do not interact with σ_r and σ_θ .
 - Compute independently and sum them.
 - Insulating materials are often strong (or at least adequate) in compression.
- A special case is a split pair solenoid which requires extra structure to bridge the gap.

Strains

- Mechanical and Thermal:

$$\varepsilon_{\theta} = \frac{\sigma_{\theta}}{E_{\theta}} - \nu_{\theta r} \frac{\sigma_r}{E_r} - \delta_{\theta} \quad \left| \quad \delta_{\theta} = \int_{300K}^{4K} \alpha_T^{\theta} dT$$

$$\varepsilon_r = \frac{\sigma_r}{E_r} - \nu_{r\theta} \frac{\sigma_{\theta}}{E_{\theta}} - \delta_r \quad \left| \quad \delta_r = \int_{300K}^{4K} \alpha_T^r dT$$

- Condition of orthotropy: $\frac{\nu_{r\theta}}{E_{\theta}} = \frac{\nu_{\theta r}}{E_r}$

$$\varepsilon_r = \frac{du}{dr}$$

$$\varepsilon_{\theta} = \frac{u}{r}$$

- Consider forces and stress distribution under **FAULT** conditions, e.g. internal short in the coil
 - This can lead to substantial, and often unsupported stresses and coil damage or destruction.

Lorentz Forces in Solenoids

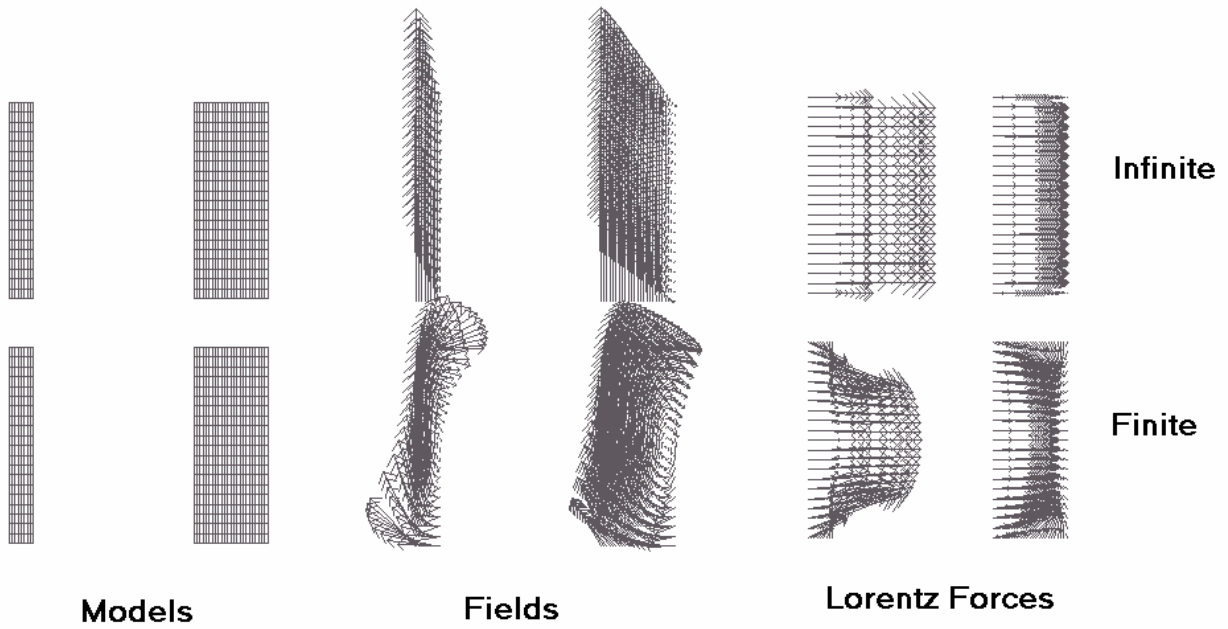

Hoop Stress in an Infinite Solenoid

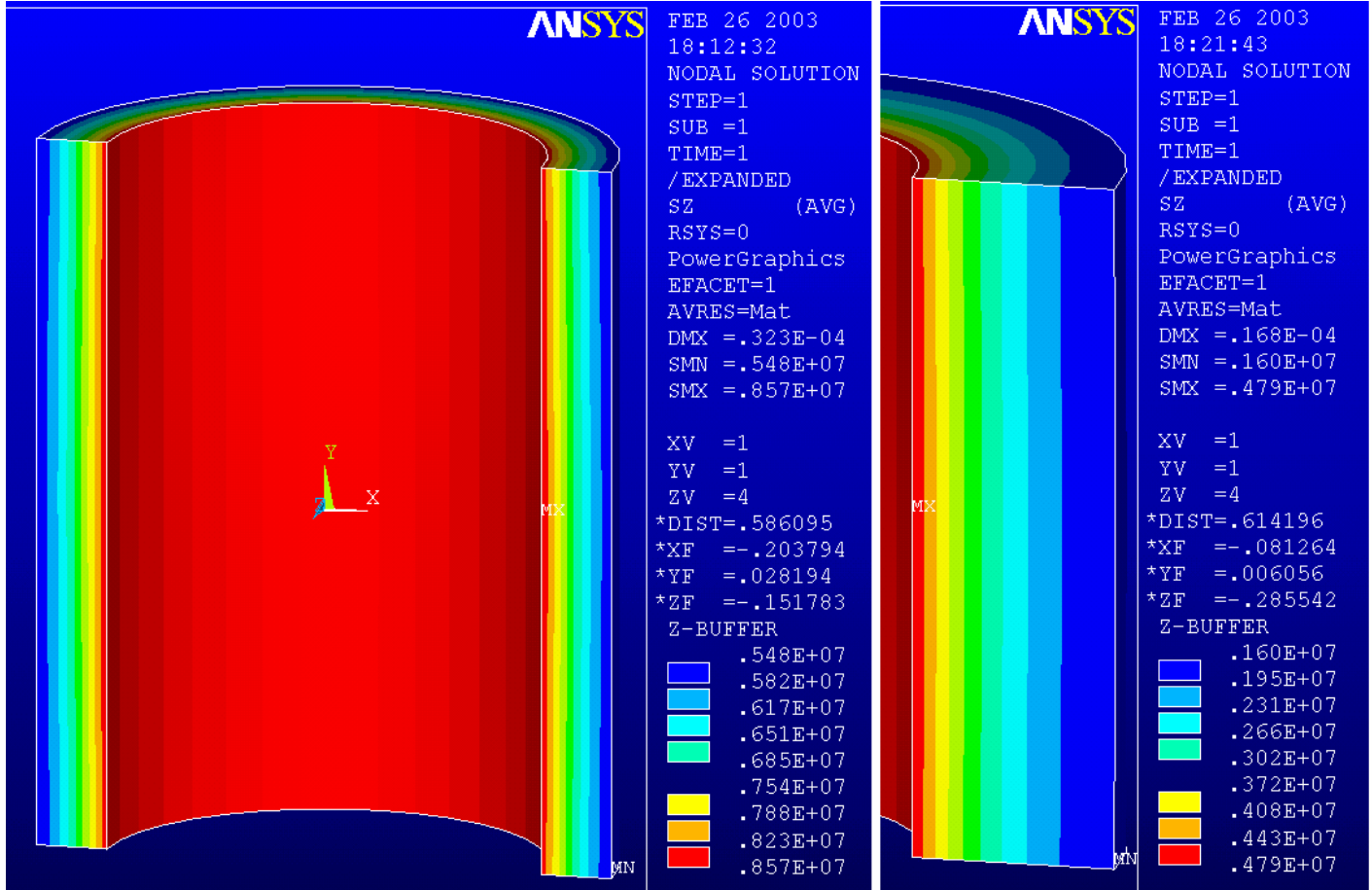

Infinite Solenoid
 R Z dR dZ
 .3 0 .1 >>1.0 (m)
 Current Density=5kA/cm²
 Bmax=5.478 Tesla

Hoop Stress in an Infinite Solenoid

*Even Though The Build is 3
 Times Greater, The Hoop
 Stress is still More than half
 the Thin Sheet Solenoid*

Infinite Solenoid
 R Z dR dZ
 .5 0 .3 >>1.0 (m)
 Current Density=1.67 kA/cm²
 Bmax=5.86 Tesla

Radial Stress in an Infinite Solenoid

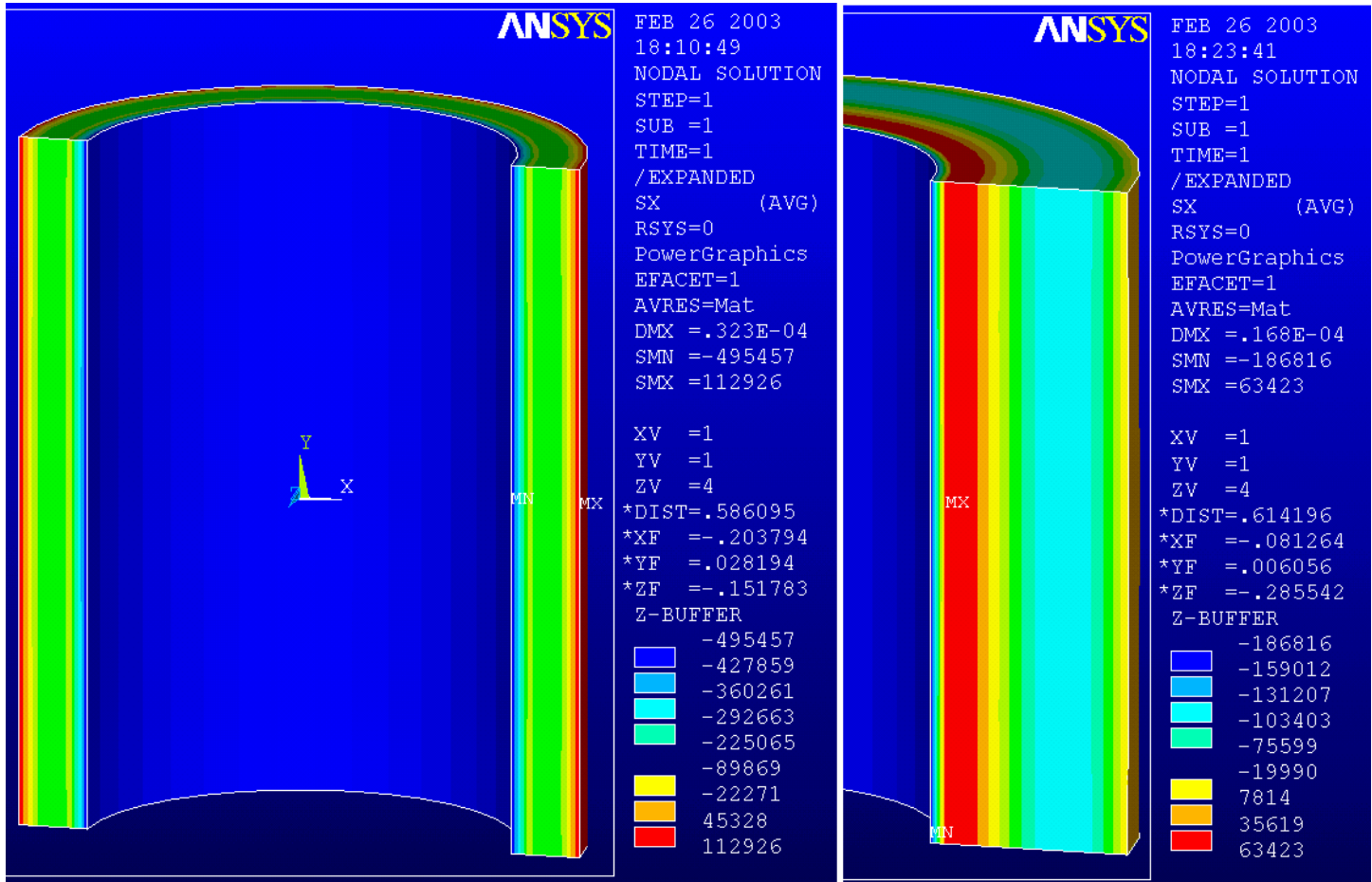

Infinite Solenoid
 R Z dR dZ
 .3 0 .1 >>1.0 (m)
 Current Density=5kA/cm²
 Bmax=5.478 Tesla

Radial Stress for an Infinite Solenoid
The Tension Stress on the OD of the Thin Sheet Solenoid is a finite mesh effect. Note Tension near ID of larger build coil

Infinite Solenoid
 R Z dR dZ
 .5 0 .3 >>1.0 (m)
 Current Density=1.67 kA/cm²
 Bmax=5.86 Tesla

Hoop Stress in a Finite Solenoid

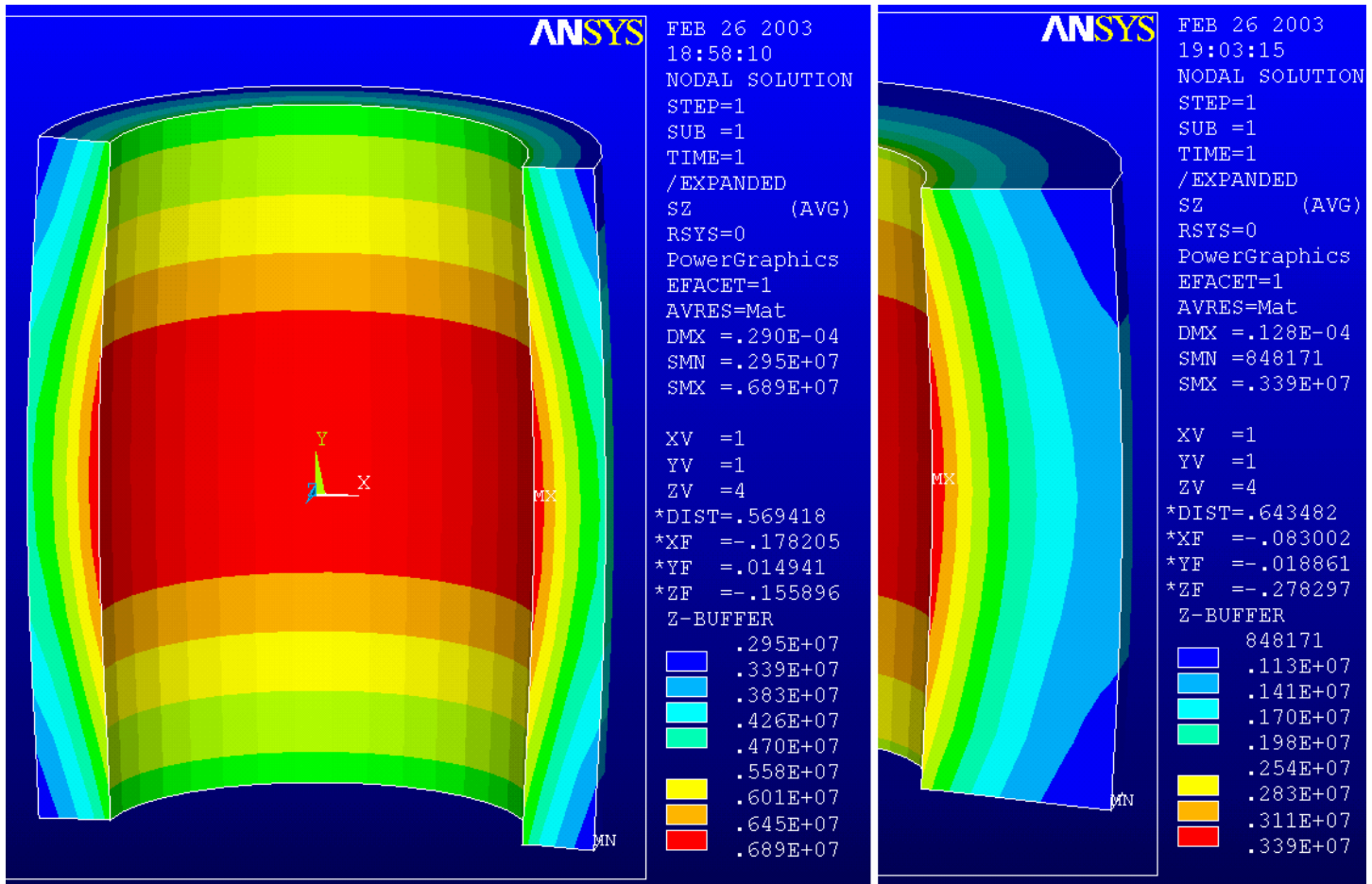

Hoop Stress in a Finite Build Solenoid

R Z dR dZ
.3 0 .1 1.0 (m)
Current Density=5kA/cm²
Bmax=5.24 Tesla

R Z dR dZ
.5 0 .3 1.0 (m)
Current Density=1.67 kA/cm²
Bmax=5.015 Tesla

Radial Stress in a Finite Solenoid

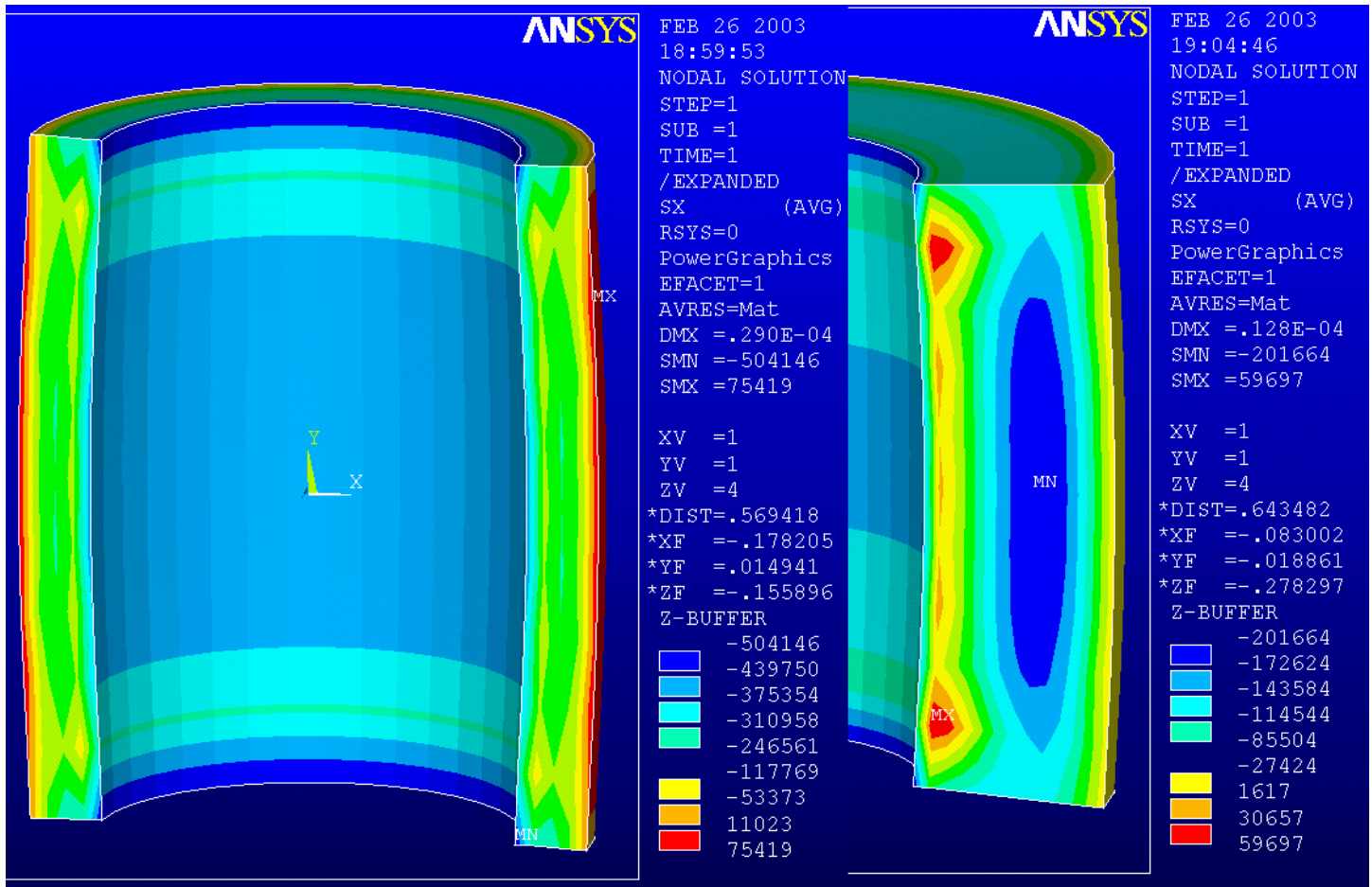

R Z dR dZ
 .3 0 .1 1.0 (m)
 Current Density=5kA/cm²
 Bmax=5.24 Tesla

Radial Stress in a Finite Solenoid
The Tension Stress on the OD of the Thin Sheet Solenoid is a finite mesh effect. Note Tension near ID of larger build coil

R Z dR dZ
 .5 0 .3 1.0 (m)
 Current Density=1.67 kA/cm²
 Bmax=5.015 Tesla

Axial Stress Comparison Infinite vs Finite

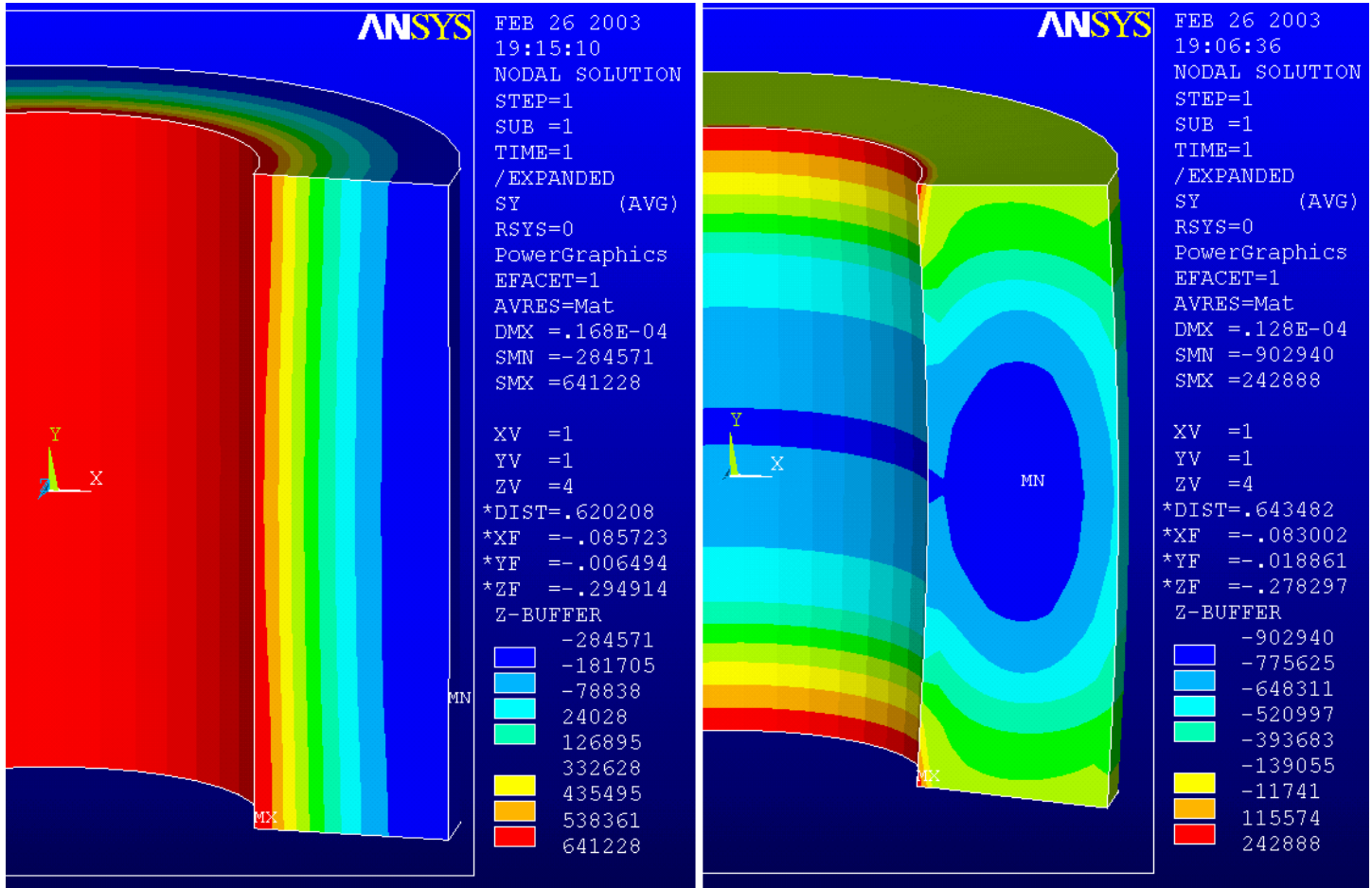

Infinite Solenoid

R Z dR dZ
 .3 0 .1 >>1.0 (m)
 Current Density=5kA/cm²
 Bmax=5.478 Tesla

Vertical Stress Comparison

Finite Solenoid

R Z dR dZ
 .5 0 .3 1.0 (m)
 Current Density=1.67 kA/cm²
 Bmax=5.015 Tesla

ITER Central Solenoid Model Coil

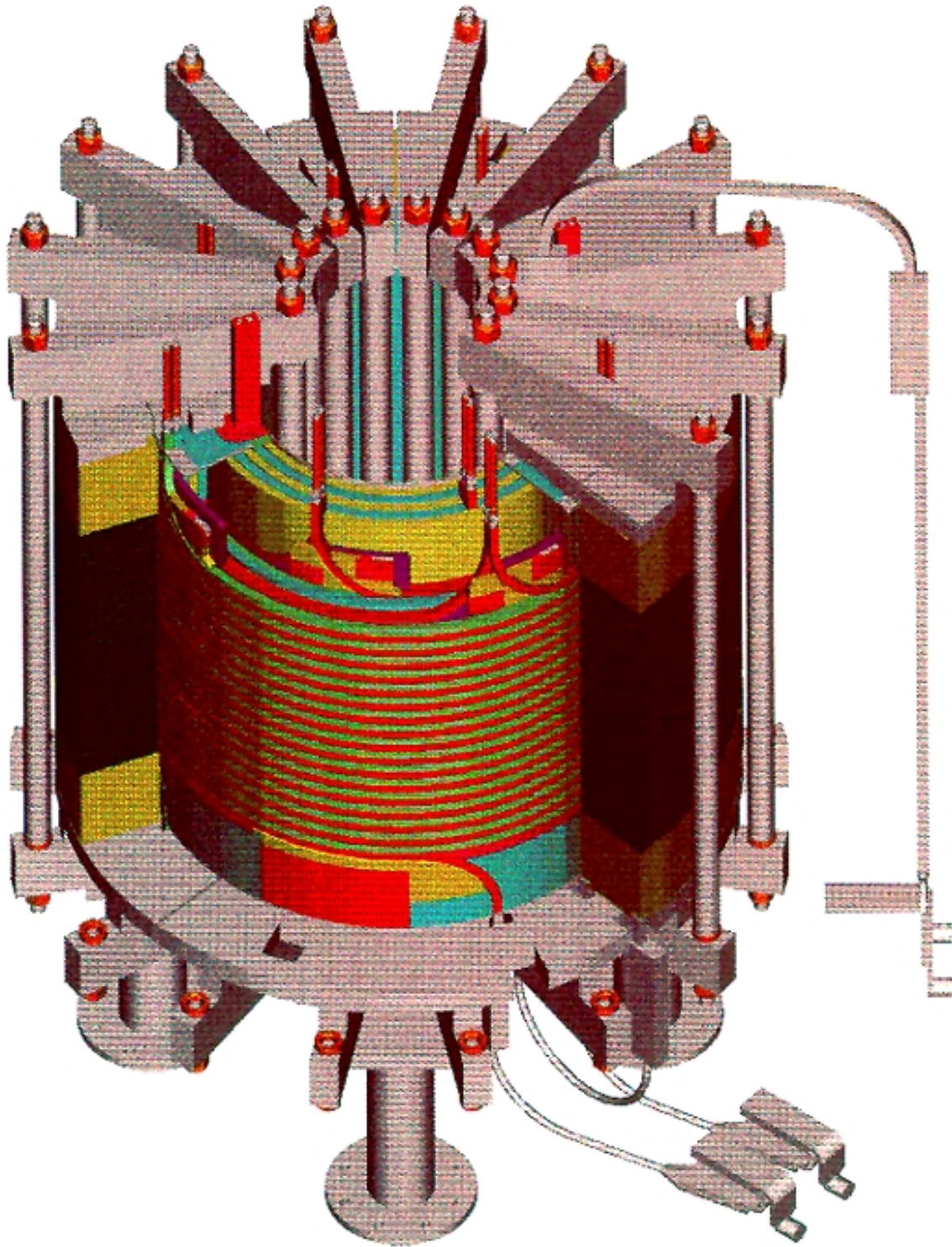

$B = 13 \text{ T}$

Internal pressure $\approx 660 \text{ atm} \approx 10,000 \text{ psi}$

Dipoles

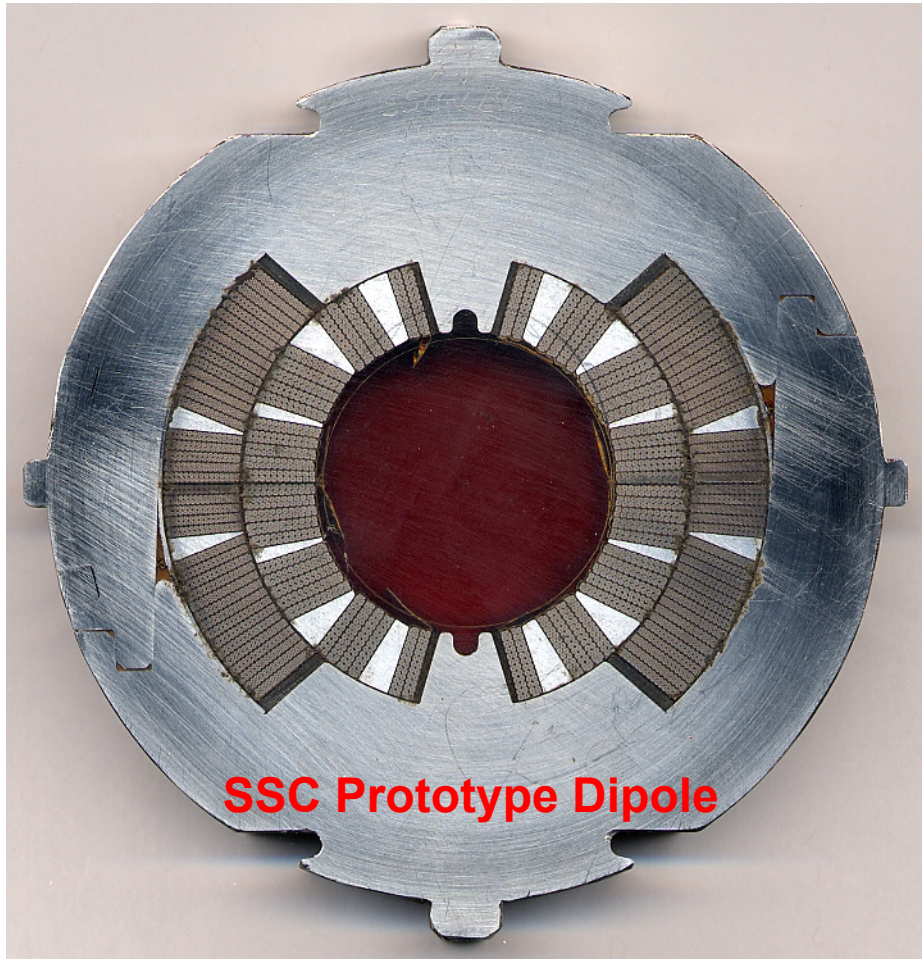

Ideal Tori with Circular Cross-Section

$$\oint \vec{H} \cdot d\vec{l} = \iint \vec{J} \cdot \vec{n} da$$

$$\frac{B_\phi}{\mu_0} \cdot 2\pi r = NI$$

$$B_\phi = \frac{\mu_0 NI}{2\pi r} \quad \text{Inside}$$

$$B_\phi = 0 \quad \text{Outside}$$

Ideal Tori with Non-Circular Cross-Section

$$\oint \vec{H} \cdot d\vec{l} = \iint \vec{J} \cdot \vec{n} da$$

$$\frac{B_\phi}{\mu_0} \cdot 2\pi r = NI$$

$$B_{in} = B_{max} \frac{r_1}{r} \quad \text{Inside}$$

$$B_{max} = \frac{\mu_0 NI}{2\pi r_1} \quad \text{Inside}$$

$$B_{out} = 0 \quad \text{Outside}$$

PF Coils and Functions

- **OH Coils – Ohmic Heating**
 - Plasma initiation
 - Plasma heating by transformer action
 - High flux linkage with plasma current
 - No or low vertical field in plasma
- **EF Coils – Equilibrium Field**
 - Create vertical field at plasma for radial equilibrium
- **Elongation Coils**
 - Elongation of Plasma
 - Double or single null
- **Shaping Coils**
 - Shape plasma to D, bean or triangular shape in conjunction with elongation coils
- **Control Coils**
 - Control plasma position both vertically and radially
 - Either inside Vacuum Vessel (VV) for fast control or outside VV for slow control
 - Used in conjunction with other PF coil functions
- **All coils are coaxial solenoids or Ring Coils**
- **All coils excited independently with time-varying currents (often bipolar) during plasma cycle**
 - Fields from coils are superposed so current supply may follow complex waveform for combining functions
- **Seldom use magnetic materials**
 - Exception: OH transformer, e.g. JET, Tore Supra (but not with SC magnets)
 - Sometimes used for TF ripple correction

ITER Coils

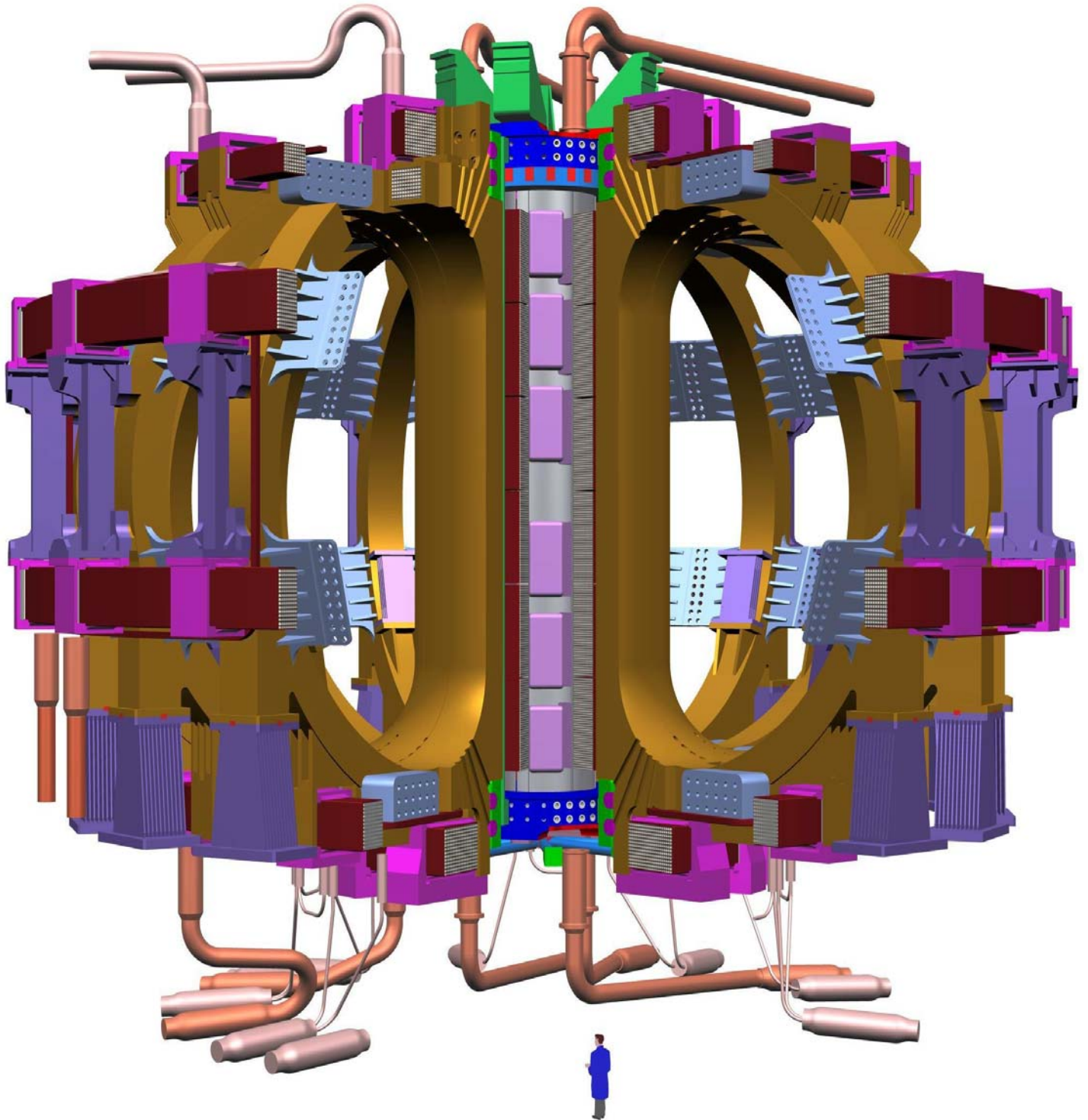

CS Currents Operation Scenario

Table 1.1.4-3 Reference Scenario

Reference scenario: Inductive operation II, (15 MA, without heating during current ramp-up).

Time sec		Plasma	CSU3	CSU2	CSU1	CSL1	CSL2	CSL3
		Current (MA)						
0.00	IM	0.0	22.00	21.99	21.56	21.56	21.99	22.00
0.92		1.10 ⁻⁵	18.48	18.79	19.94	19.94	18.79	18.48
1.58		0.397	16.42	16.94	18.91	18.91	16.94	16.42
1.98		0.59	15.31	15.93	18.29	18.29	15.93	15.31
11.38		3.50	13.35	13.75	8.24	8.24	12.99	17.12
15.24		4.50	11.73	12.25	5.54	5.54	11.24	16.71
19.52		5.50	10.10	10.76	3.05	3.05	9.49	16.29
24.17		6.50	8.47	9.26	0.72	0.72	7.75	15.88
29.37	XPF	7.50	6.84	7.76	-1.69	-1.69	6.00	15.46
35.25		8.50	6.60	5.58	-4.33	-4.33	4.16	14.19
42.12		9.50	5.84	3.34	-6.94	-6.94	2.42	12.99
49.26		10.50	5.33	1.10	-9.52	-9.52	0.69	11.80
56.21		11.50	4.81	-1.15	-12.03	-12.03	-1.05	10.60
63.22		12.50	4.29	-3.39	-14.54	-14.54	-2.79	9.41
72.55		13.50	3.78	-5.64	-16.98	-16.98	-4.53	8.21
100.00	SOF	15.00	3.00	-9.00	-20.56	-20.56	-7.13	6.42
130.00	SOB	15.00	-0.40	-9.68	-20.09	-20.09	-9.50	3.22
530.00	EOB	15.00	-0.78	-20.15	-23.90	-23.90	-18.01	-0.47
552.22		14.00	-0.27	-21.67	-23.89	-23.89	-17.47	-0.92
574.44		13.00	0.24	-22.78	-23.76	-23.76	-17.10	-1.36
590.00	EOC	12.30	0.60	-23.70	-23.52	-23.52	-16.81	-1.67
616.00		10.00	-1.60	-23.10	-21.31	-21.31	-16.84	-3.07
647.20		7.00	-4.48	-20.11	-17.59	-17.59	-15.87	-4.88
668.00		5.00	-6.39	-17.74	-14.68	-14.68	-14.99	-6.10
688.80		3.00	-8.21	-14.48	-12.72	-12.72	-12.86	-7.25
709.60		1.00	-10.23	-9.74	-9.74	-9.74	-9.74	-8.52
720.00	EOP	0.00	-10.5	-10.00	-10.00	-10.00	-10.00	-9.00
900.00	Dwell	0.00	0.0	0.0	0.0	0.0	0.0	0.0
1,490.0	Dwell	0.0	0.0	0.0	0.0	0.0	0.0	0.0
1,790.0		0.0	22.00	21.99	21.56	21.56	21.99	22.00
1,800.0	IM	0.0	22.00	21.99	21.56	21.56	21.99	22.00

PF Currents Operation Scenario

Time		PF1	PF2	PF3	PF4	PF5	PF6
sec		Current (MA)					
0.00	IM	11.21	0.998	-0.012	0.8296	-0.848	13.01
0.92		11.10	-0.11	0.37	0.42	-1.34	11.95
1.58		10.93	-0.22	0.26	0.27	-1.14	11.18
1.98		10.81	-0.27	0.19	0.15	-1.05	10.74
11.38		9.95	-2.16	0.46	-1.42	-1.78	10.85
15.24		10.07	-2.37	0.19	-1.90	-2.20	11.63
19.52		10.18	-2.28	-0.53	-1.85	-3.06	12.42
24.17		10.30	-2.30	-1.11	-1.87	-3.92	13.21
29.37	XPF	10.46	-1.94	-2.06	-1.94	-4.55	14.00
35.25		9.74	-2.00	-2.49	-2.26	-4.98	14.45
42.12		9.08	-2.09	-2.90	-2.60	-5.39	14.90
49.26		8.43	-2.18	-3.33	-2.90	-5.81	15.35
56.21		7.78	-2.28	-3.75	-3.19	-6.23	15.80
63.22		7.12	-2.37	-4.21	-3.44	-6.67	16.25
72.55		6.47	-2.46	-4.67	-3.68	-7.11	16.70
100.00	SOF	5.49	-2.62	-5.37	-3.99	-7.79	17.38
130.00	SOB	4.91	-2.04	-6.52	-4.69	-7.54	17.20
530.00	EOB	1.74	-1.97	-6.70	-4.83	-7.67	15.00
552.22		1.04	-1.69	-6.12	-4.56	-6.85	12.98
574.44		0.33	-1.56	-5.41	-4.38	-5.99	10.96
590.00	EOC	-0.16	-1.44	-4.92	-4.28	-5.39	9.55
616.00		-1.25	-1.49	-3.93	-3.57	-4.49	6.23
647.20		-2.67	-1.69	-2.41	-2.77	-3.17	1.90
668.00		-3.61	-1.57	-1.65	-1.89	-2.48	-0.99
688.80		-4.51	-0.90	-1.23	-1.12	-1.32	-3.88
709.60		-5.50	-0.41	-0.48	-0.46	-0.07	-6.77
720.00	EOP	-6.00	-0.40	-0.40	-0.40	0.00	-7.00
900.00	Dwell	0.0	0.0	0.0	0.0	0.0	0.0
1,490.0	Dwell	0.0	0.0	0.0	0.0	0.0	0.0
1,790.0		11.21	0.998	-0.012	0.8296	-0.848	13.01
1,800.0	IM	11.21	0.998	-0.012	0.8296	-0.848	13.01

CS and PF Currents Operation Scenario

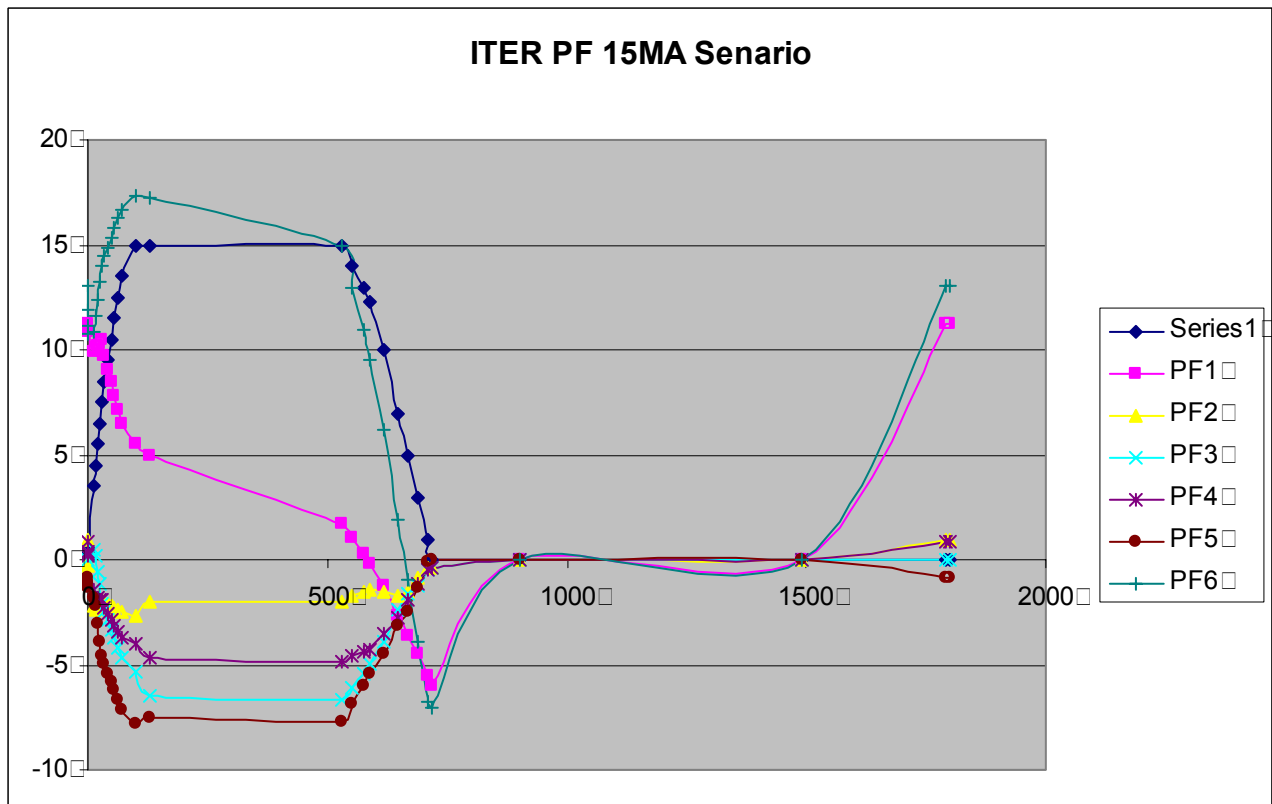
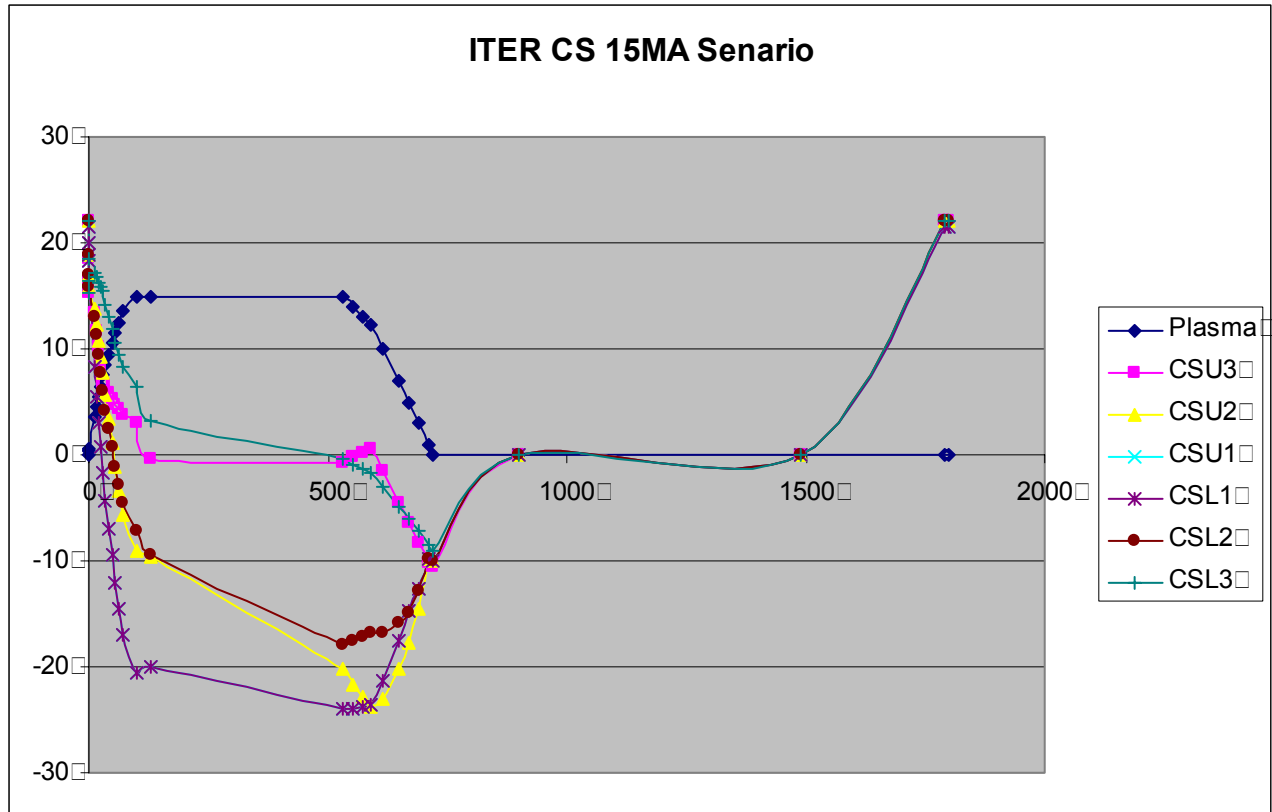

Out-Of-Plane (OOP) Forces in TF Coils

- Under usual operating conditions there are no out-of-plane loads on a TF coil due to other TF coils
- Watch out for *fault* conditions (e.g. unequal currents)

TF Forces

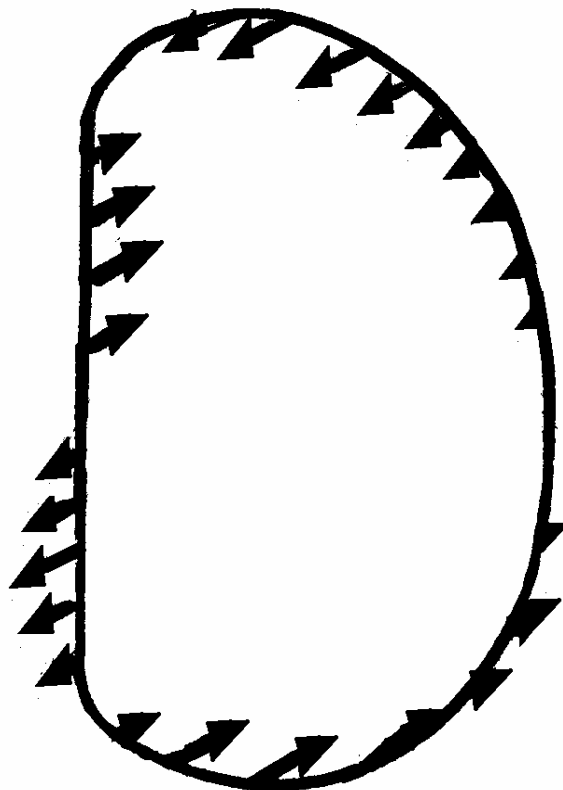
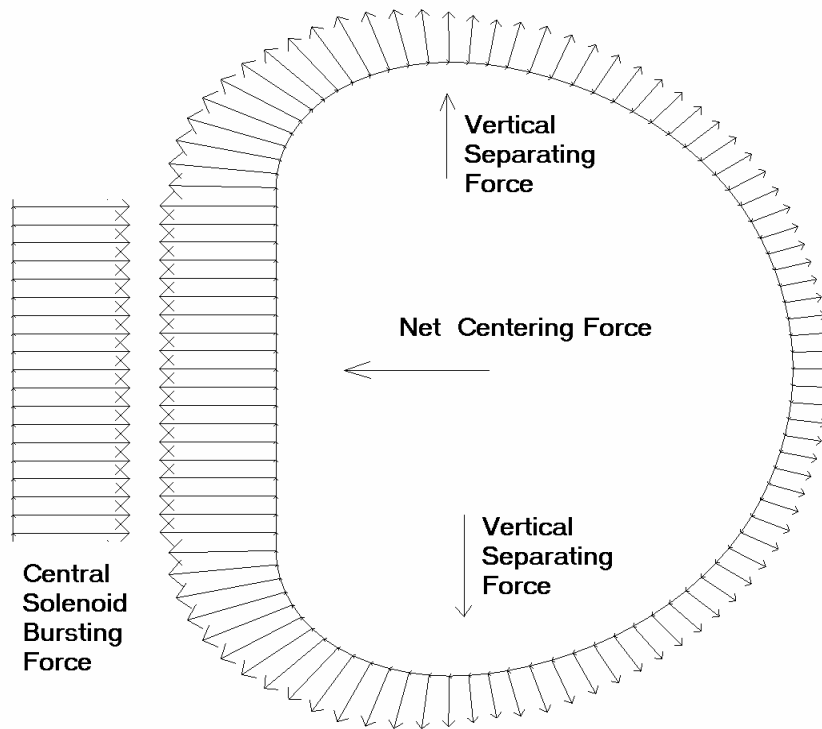

OOP in TF Coils

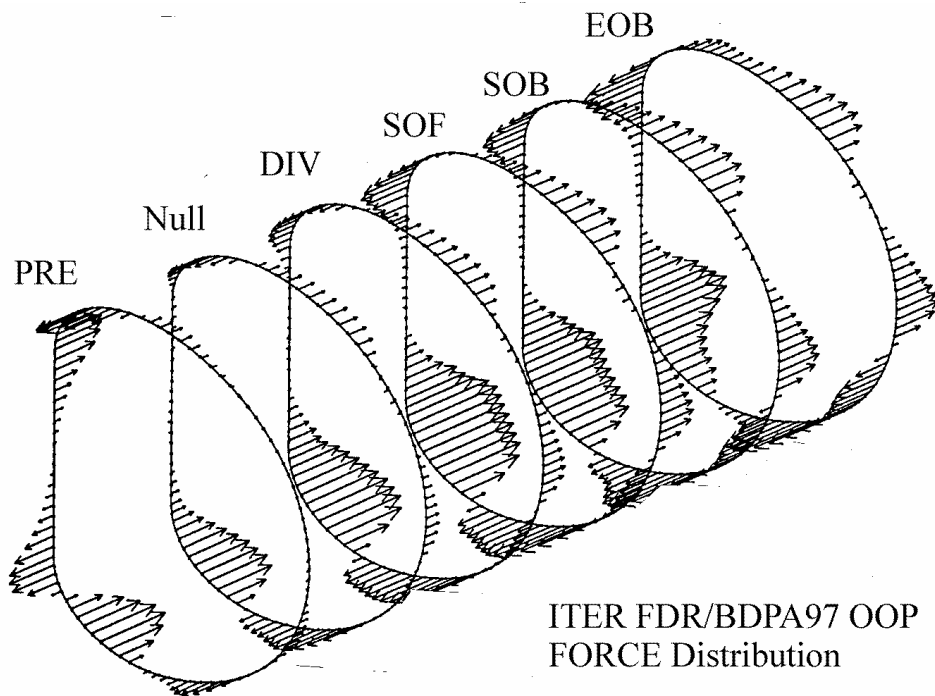

Force Calculation

$$dF = \frac{1}{2} (I \times B) ds$$

$$F_z = \mu_o \frac{NI^2}{4\pi} \left(\frac{1 + \gamma}{1 - \gamma} \right)$$

where $\gamma = \frac{\rho}{r_{av}} = \frac{\text{minor radius}}{\text{major radius}}$

Note : $\gamma < 1$

$$F_r = \frac{\mu_o NI^2}{2} \left[1 - \frac{1}{\sqrt{(1 - \gamma^2)}} \right]$$

Note : Since $\gamma < 1 \longrightarrow F_r < 0$ (Centering Force)

$$\rho = kr$$

$$k = \frac{2T}{IB_m r_1} = \frac{4\pi T}{\mu_o NI^2}$$

$$\rho = \pm \frac{\left[1 + \left(\frac{dr}{dz} \right)^2 \right]^{3/2}}{\frac{d^2 r}{dz^2}}$$

Combine the 3 equations:

$$r \frac{d^2 r}{dz^2} = \pm \frac{1}{k} \left[1 + \left(\frac{dr}{dz} \right)^2 \right]^{3/2}$$

$$r_1 = r_o e^{-k}, \quad r_2 = r_o e^{+k}$$

$$r_o = \sqrt{r_1 r_2}$$

$$k = \frac{1}{2} \ln(r_2 / r_1)$$

Comments About Constant Tension Tori

$$NF_z = \frac{B_m^2 \pi r_1^2}{\mu_0} \ln(r_2 / r_1)$$

F_z = Z - directed force/coil half

N = number of coils in torus

- This shows why structural design becomes more difficult as size and magnetic field increase

$$F_z \propto (B_m r_1)^2$$

- Note also that F_z depends only on r_1 and r_2 , not on shape of torus.
- For equilibrium $T_c - T_d = \frac{\mu_0 I^2}{4\pi} (k_C - k_D)$

Comments About Constant Tension Tori

- Methods of connection and supports affect constant T characteristics and generate bending moments.
- Each coil segment is constant T, but not momentless unless coil reactions respond to loads in a particular way:
 - Must account for shape change in response to EM loads + reactions.
 - Must take account of actual coil and structure stiffness and cross-sections.
 - Must account for discreteness of coils in toroidal direction.
 - Actual location and size of coil supports is affected by overall Tokamak design:
 - Size, location of plasma, VV, shields, ports, maintenance access, etc.
 - In general, a 3D analysis of loads and stresses must be made.

Alcator C-Mod

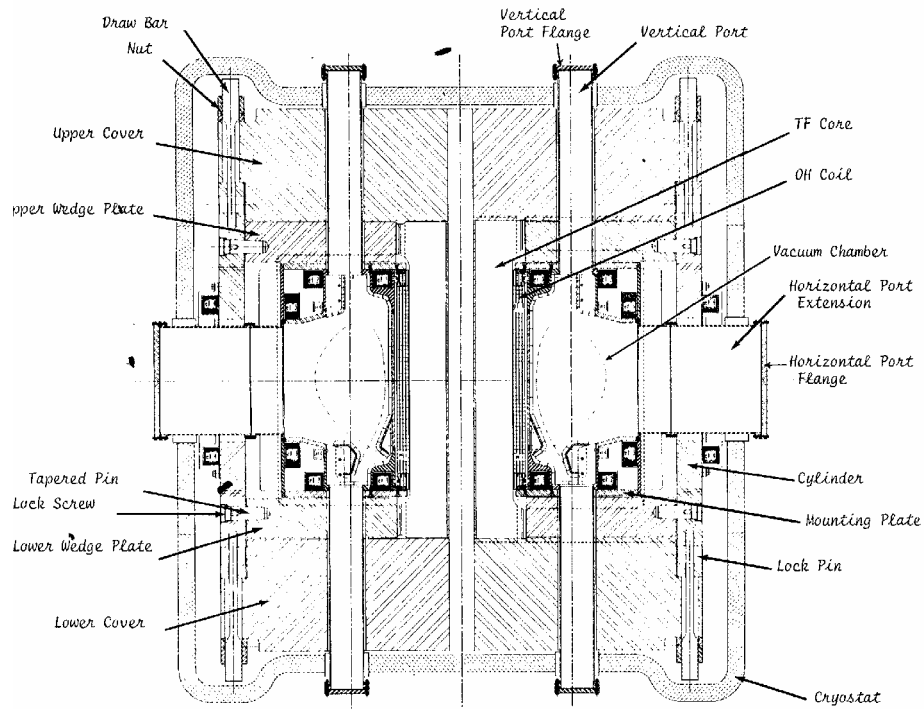

Alcator C-Mod Cross Section/Elevation View - Structural Elements

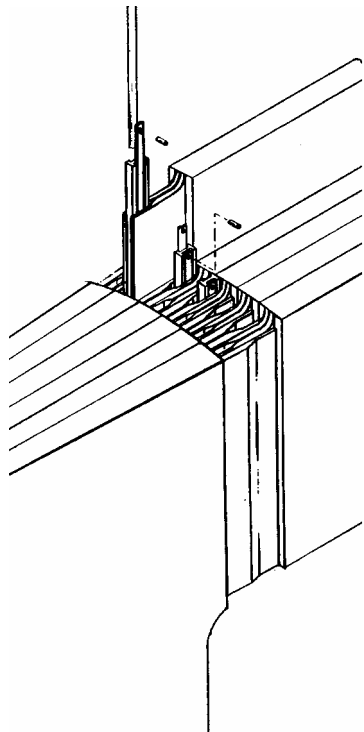

Sliding finger joints in Alcator C-Mod

3D FEA

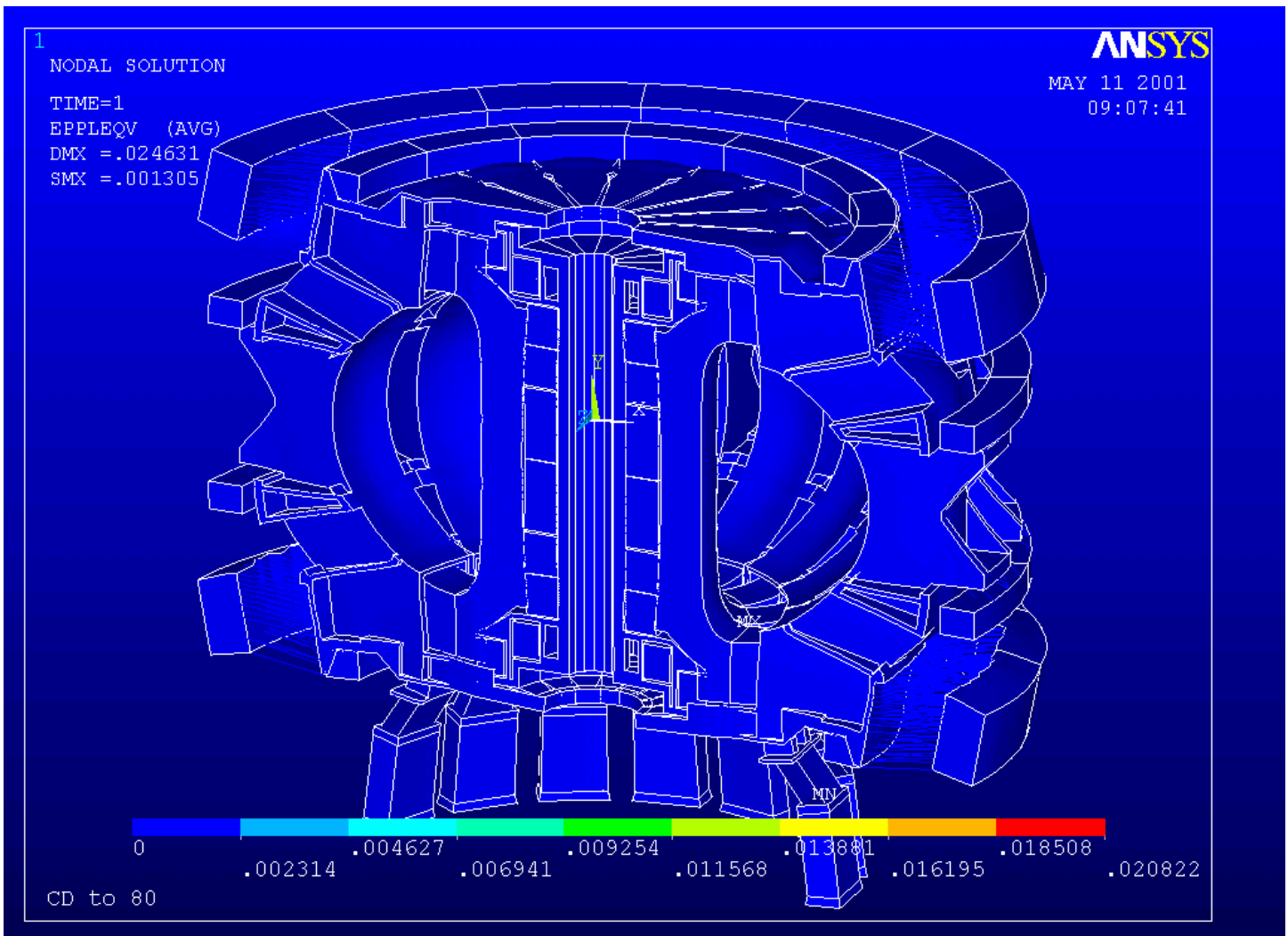

FIRE Model