

Measurement Sheet

Lab #10: Organic Photovoltaics

MIT Nanomaker_Spring 2013

Experiment #1: Measuring the absorption spectrum of natural dyes

You have been given three natural dyes: 1) pomegranate seeds, 2) raspberries, 3) blueberry.

Each dye has been placed at the bottom of a square, transparent petri dish. Use the petri dishes to measure the absorption spectrum of each dye by back-illuminating each dish with a white light source and measuring the spectrum of the filtered light.

Hint: by measuring the spectrum at the edge of the dish, you can capture both the unfiltered and filtered light spectra simultaneously. The diagram below may serve as a useful guide.

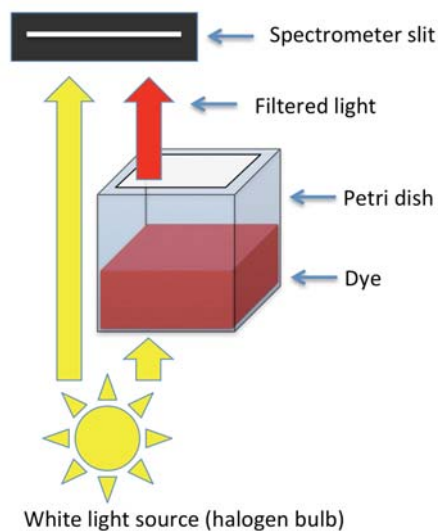

Determine the peak absorption wavelength(s) of each dye.

- i) Pomegranate peak absorption wavelength(s): _____
- ii) Raspberry peak absorption wavelength(s): _____
- iii) Blueberry absorption wavelength(s): _____

Experiment #2: Characterizing the dye-sensitized PV cell

Follow the web instructions for constructing the dye-sensitized PV cell. Each member of your three-person group will have to choose one of the aforementioned dyes, such that each group will have data for all three dyes. Then, for each dye-sensitized cell, measure values for open-circuit voltage and short-circuit current as a function of illumination incident angle using the halogen lamp as a light source (see schematic).

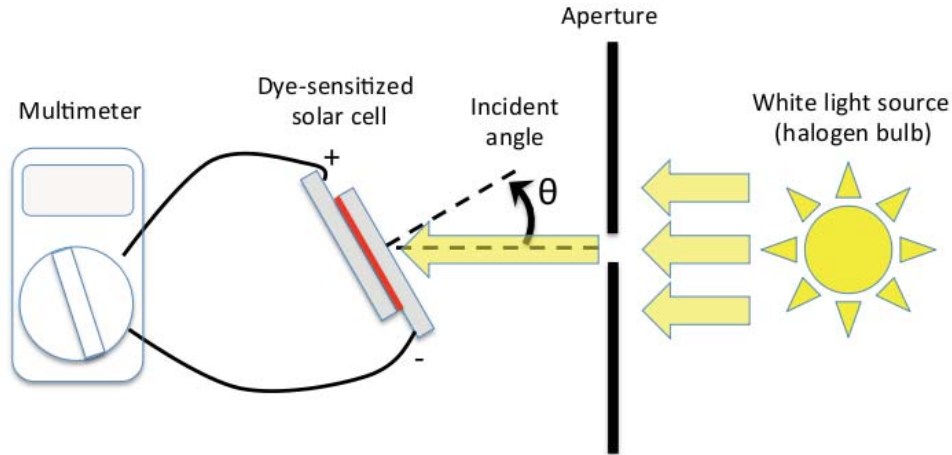

↓ Illumination incident angle	Pomegranate		Raspberry		Blueberry	
	Short Ckt (I)	Open Ckt (V)	Short Ckt (I)	Open Ckt (V)	Short Ckt (I)	Open Ckt (V)
0°						
15°						
30°						
45°						

Follow-up Questions:

- How might it be possible to improve the efficiency of the dye-sensitized cell by mixing different dyes?
- Instead of mixing dyes, consider what would happen if you stacked two separate cells: one made of a dye that has an absorption peak in the blue, while the other is made of a dye that has an absorption peak in the red. How would you stack the cells to maximize efficiency?
- Polymer solar cells are a type of flexible solar cell. They can come in many forms including: organic solar cell. We can change the conductivity of the polymer by introducing dopants. Which one is p-type doped polymer and which is n-type doped polymer. And what do people usually use as dopants for p-type doped polymer and n-type doped polymer?

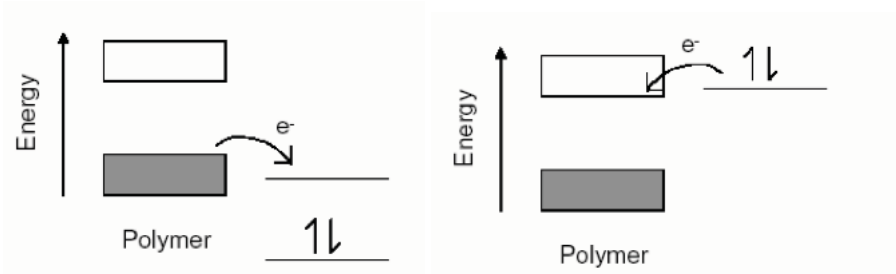

- It takes four steps to generate energy in organic solar cells. What are the four steps? What one/ones limit(s) the efficiency of solar cells?

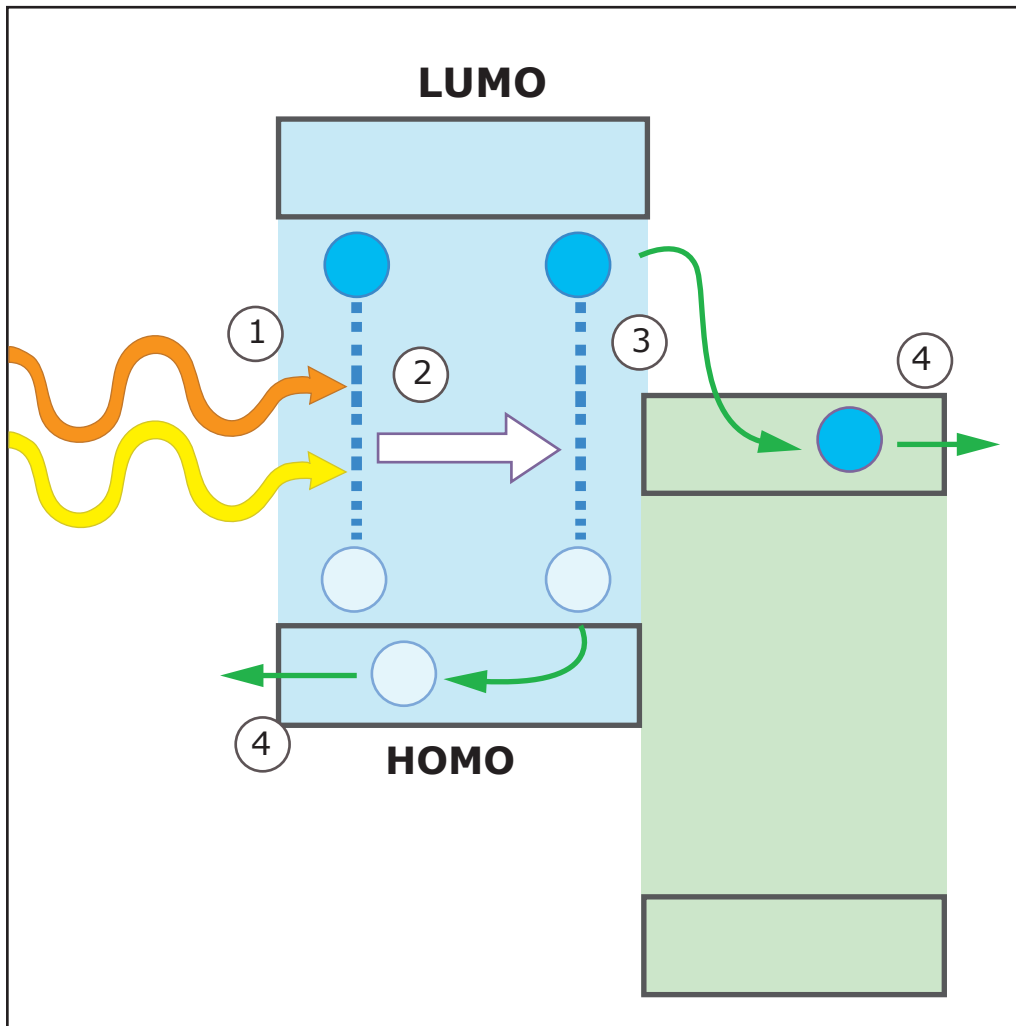

Image by MIT OpenCourseWare.

MIT OpenCourseWare
<http://ocw.mit.edu>

6.S079 Nanomaker
Spring 2013

For information about citing these materials or our Terms of Use, visit: <http://ocw.mit.edu/terms>.