

# State feedback, observer-based feedback

**6.011, Spring 2018**

**Lec 11**

# System (“plant”)

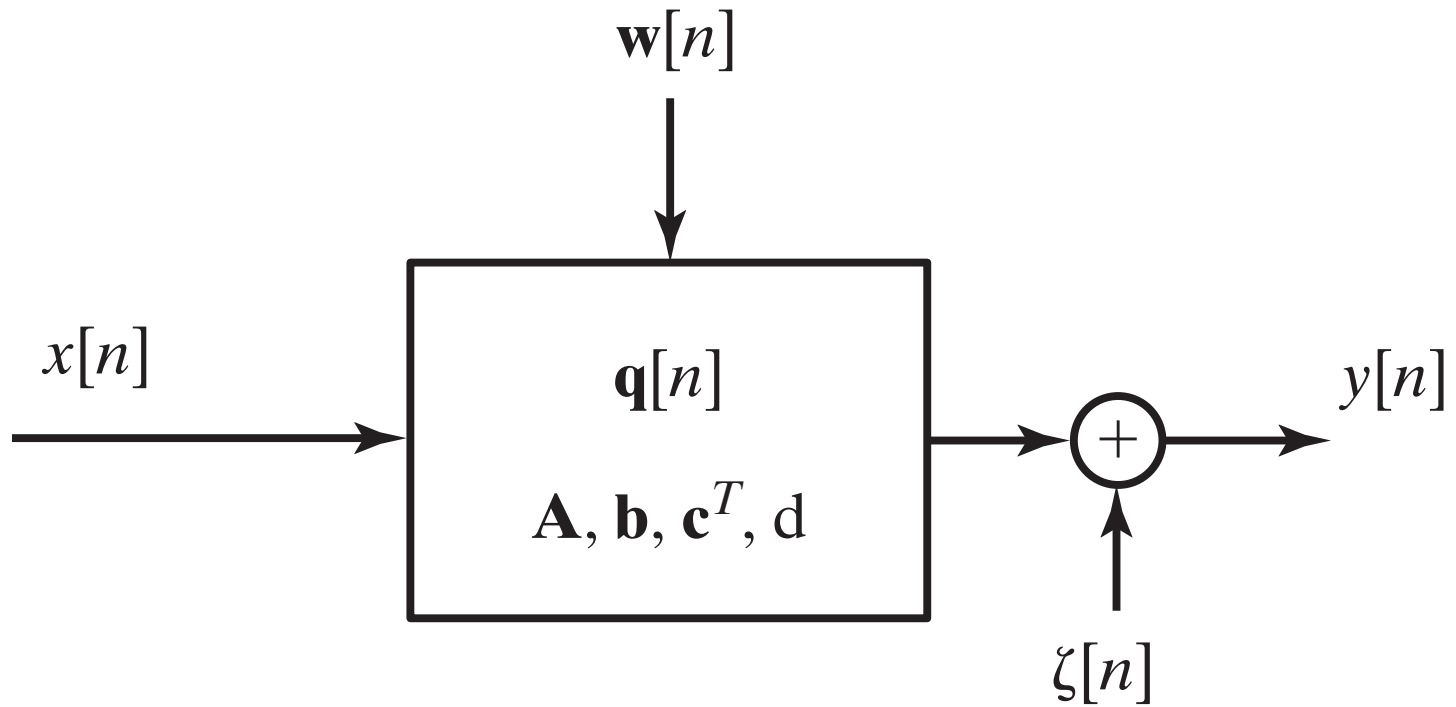

# A good model

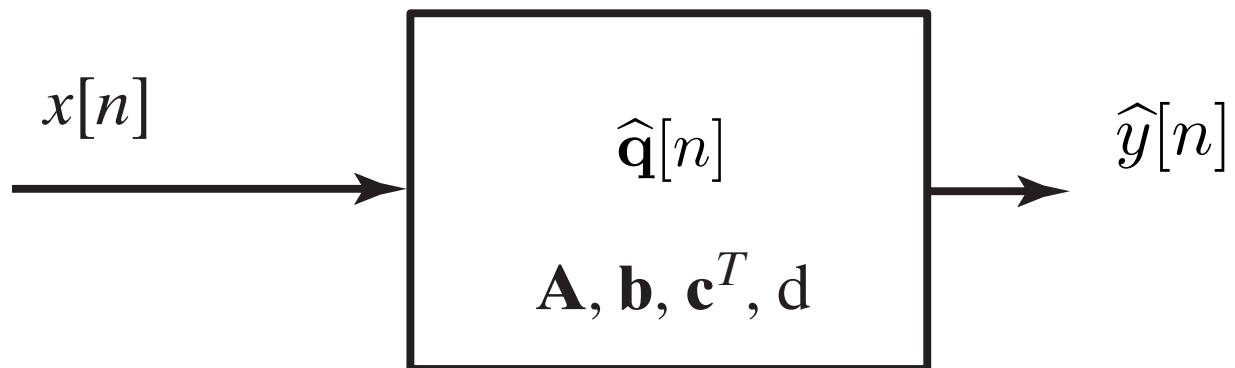

# Observer configuration

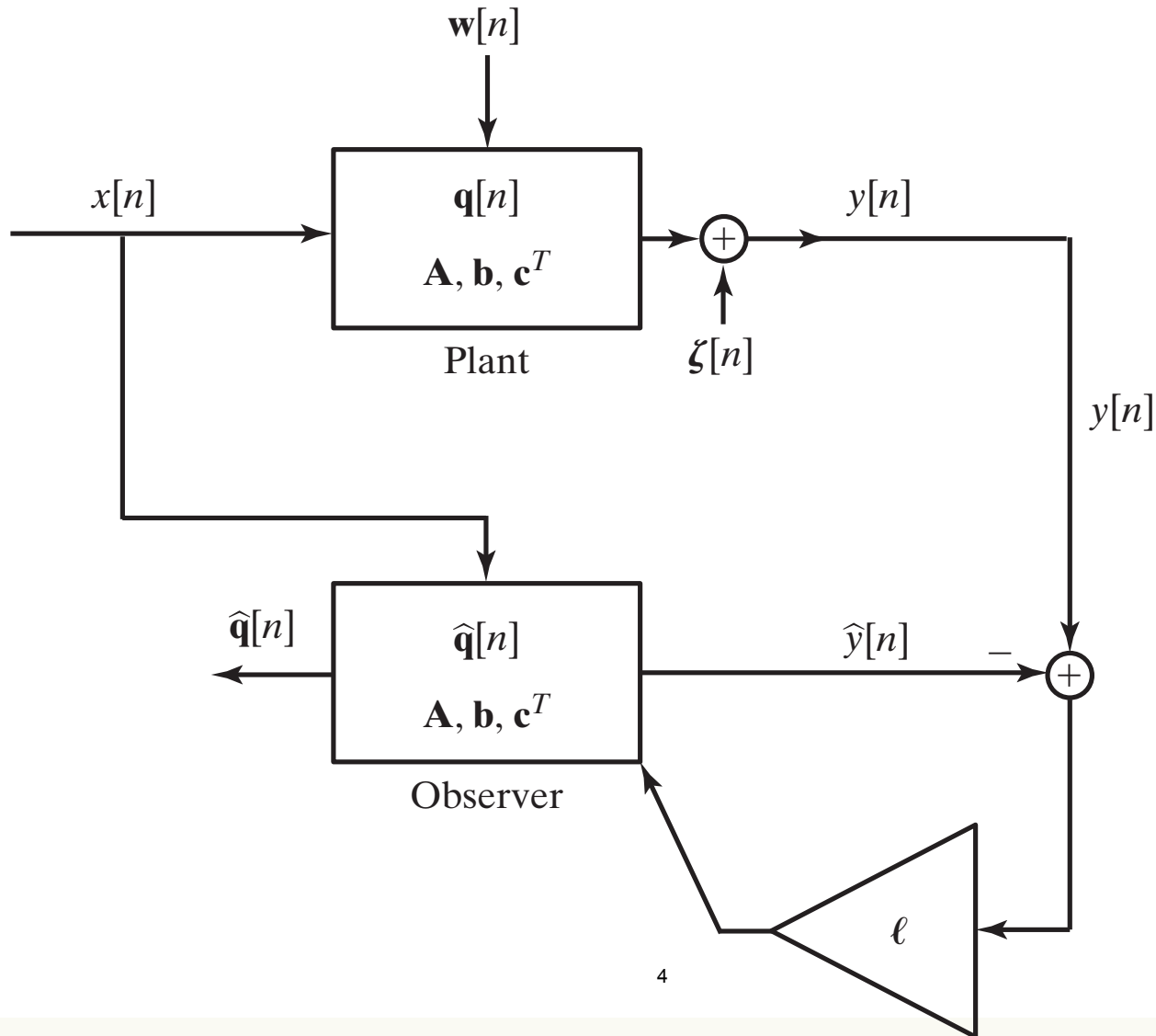

# State feedback

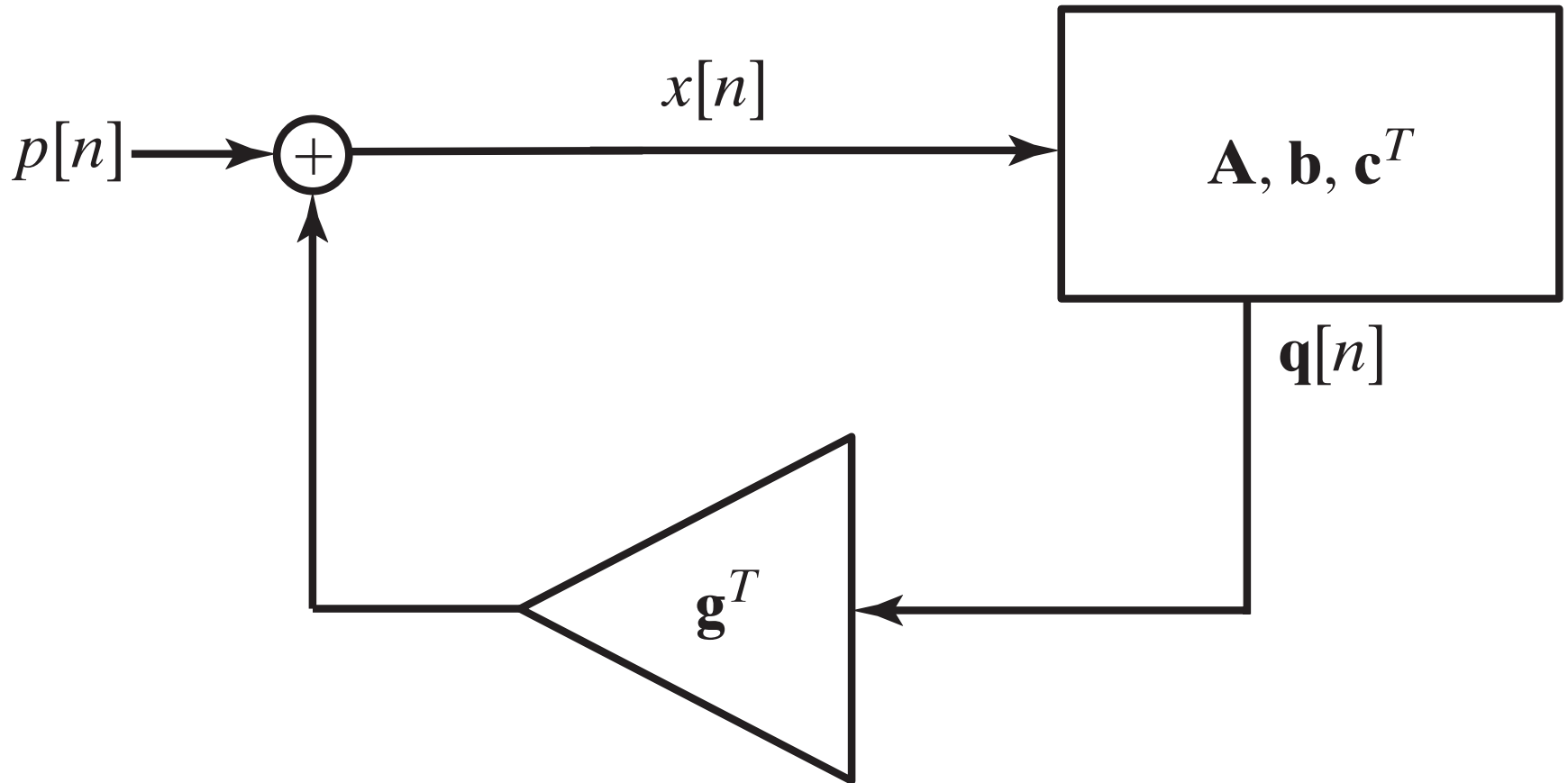

# Observer-based controller

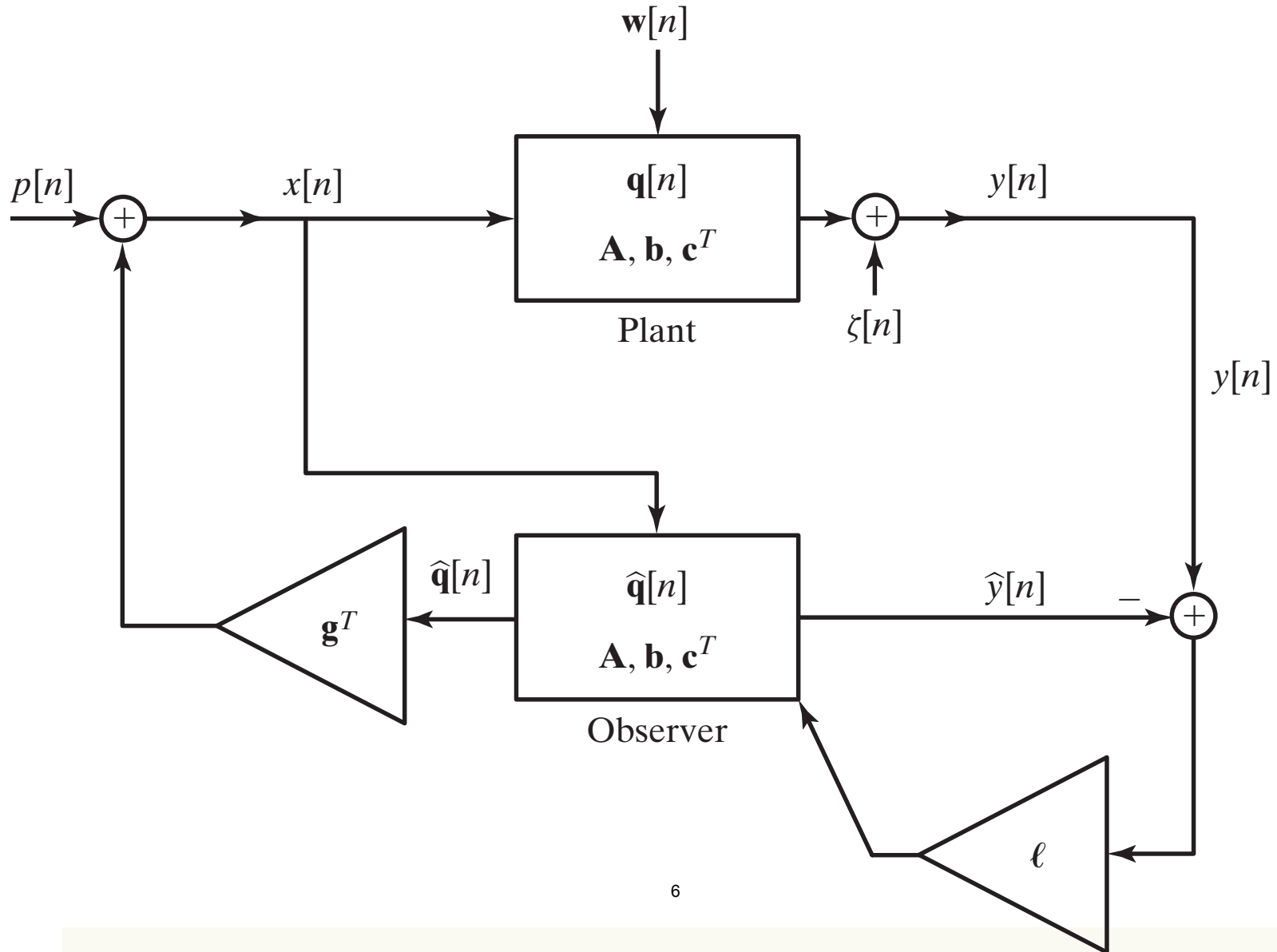

# Control of inverted Pendulum

Observer-based controller:

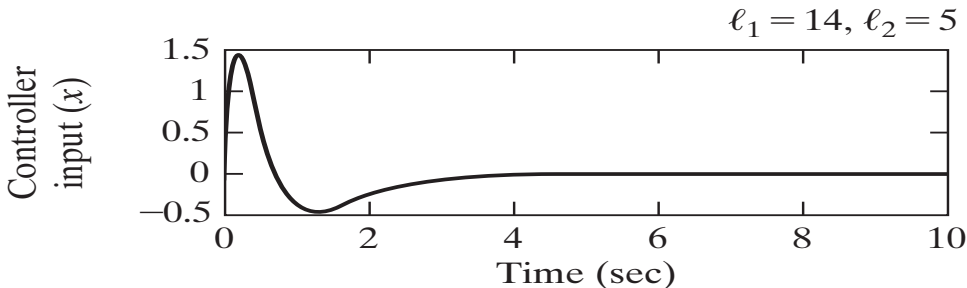
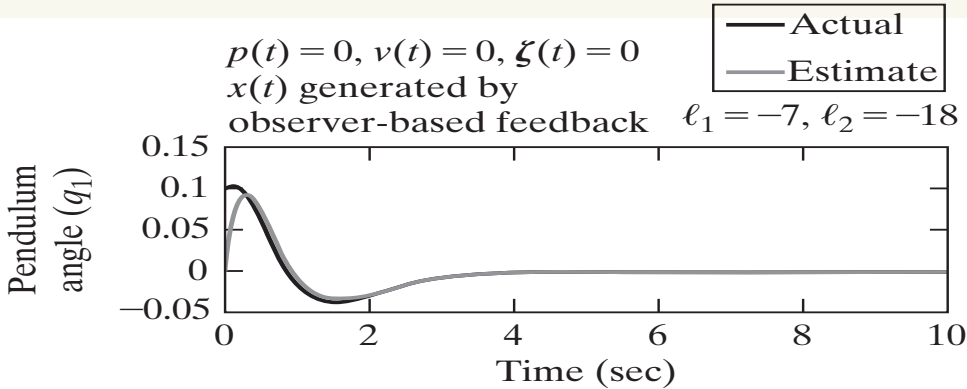

State feedback control:

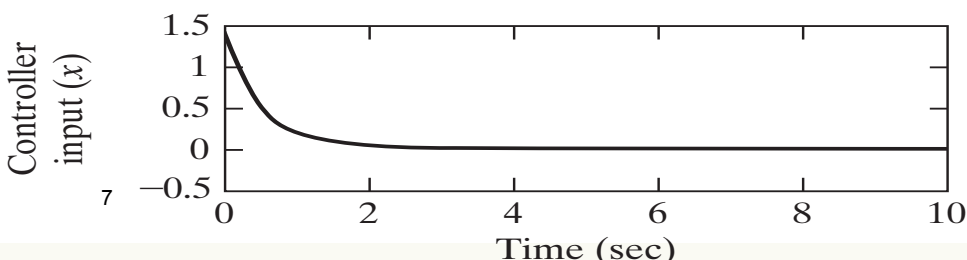
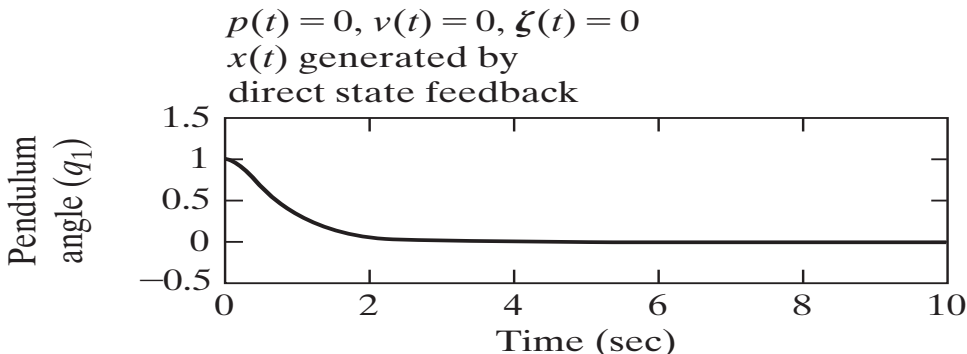

MIT OpenCourseWare  
<https://ocw.mit.edu>

6.011 Signals, Systems and Inference  
Spring 2018

For information about citing these materials or our Terms of Use, visit: <https://ocw.mit.edu/terms>.